

Part 6  
FRONT END and  
STEERING GEAR  
P 120, P 1800

**CARS**

**SERVICE  
MANUAL**

# CONTENTS

## GROUP 60, WHEEL ALIGNMENT

Wheel alignment .....	1
Measuring and adjusting wheel alignment .....	2
Checks to be carried out before adjusting .....	2
Adjusting caster .....	3
Adjusting camber .....	3
Checking king pin inclination .....	5
Checking toe-out .....	5
Adjusting toe-in .....	5
Adjusting steering limits .....	6

## GROUP 62, FRONT AXLE

Front axle .....	6
Description .....	6
Repair instructions .....	9
Removing and fitting the complete front end .....	9
Replacing stub axle .....	10
Reconditioning the wishbone system .....	11
Replacing upper ball joint .....	11
Replacing lower ball joint .....	11
Replacing upper wishbone bushes .....	12
Replacing upper wishbone .....	12
Replacing lower wishbone bushes .....	13
Replacing lower wishbone .....	13

## GROUP 64, STEERING GEAR

Steering gear .....	14
Description .....	14
Repair instructions .....	17
Replacing steering wheel, P 120 .....	17
Replacing steering wheel, P 1800 .....	17
Steering box, removing .....	18
Steering box, dismantling .....	19
Steering box, inspecting .....	19
Steering box, assembling .....	20
Steering box, installing .....	21
Reconditioning steering rod and tie rod .....	22
Replacing jacket tube and jacket tube mountings, P 120 .....	22
Replacing jacket tube and jacket tube mountings, P 1800 .....	23
Reconditioning relay arm and bracket .....	23
Removing .....	23
Dismantling .....	24
Assembling .....	24
Installing .....	24
Fault tracing .....	25
Tools .....	26
Specifications .....	28

## GROUP 60

## WHEEL ALIGNMENT

In order for the vehicle to have good steering properties and a minimum of tyre wear, the front wheels must have certain pre-determined settings, generally known as wheel alignment. Wheel alignment consists of caster, camber, king pin inclination, toe-out and toe-in.

**CASTER**

Caster generally refers to the longitudinal inclination (forwards or backwards) of the king pin. On these vehicles, which do not have a king pin, caster consists of the angle between a vertical line and a line through the centre of the ball joints (A, Fig. 1).

Caster has the effect of causing the wheels to run straight forwards thereby facilitating steering.

**CAMBER**

Camber is the inclination of the wheel itself outwards or inwards. Camber is positive if the wheel is inclined outwards (C, Fig. 2) and negative if the wheel inclines inwards. Faulty camber causes uneven tyre wear.

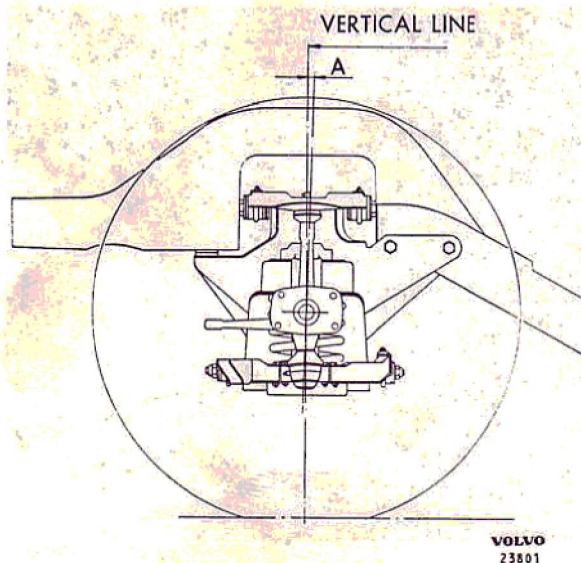

Fig. 1. Caster.

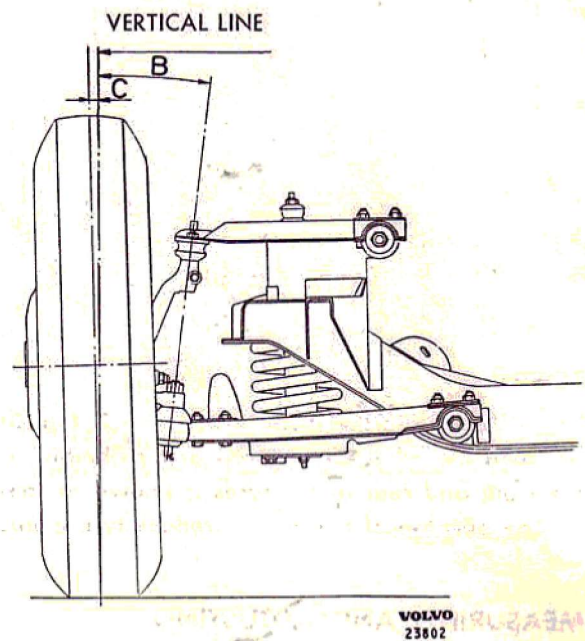

Fig. 2. Camber and king pin inclination.

B = King pin inclination  
C = Camber

**KING PIN INCLINATION**

King pin inclination means the inclination of the king pin inwards. Since these cars do not have a king pin, the inclination is represented by the angle made between a vertical line and a line through the centre of the ball joint (B, Fig. 2).

King pin inclination causes the centre lines of the ball joints and the wheel to approach each other towards the road surface. In this way the wheels are easier to turn. The inclination also assists the tendency of the wheel to run straight forwards since the car is lifted very slightly when the wheels are turned.

**TOE-OUT**

When driving round a bend the wheels roll at different radii. In order for them to have the same pivoting centre, and consequently minimum tyre wear, the front wheels must be turned to different extents. This relationship, known as toe-in, is determined by the shape of the steering rod and steering arms, see Fig. 3.

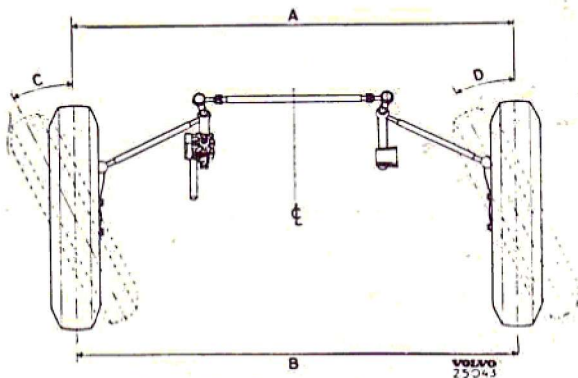

Fig. 3. Toe-out and toe-in  
(Toe-in = B-A).

### TOE-IN

The difference in the distances (A and B, Fig. 3) between the wheels measured at hub height at the front and rear of the tyres is known as toe-in. The purpose of toe-in is to reduce tyre wear.

### MEASURING AND ADJUSTING WHEEL ALIGNMENT

Wheel alignment is measured with special measuring instruments of which there are many different types. No general description can therefore be given as to how measuring should be carried out except in the case of toe-out. The measuring principle is that camber is measured directly with the wheels pointing straight forwards. Caster and king pin inclination cannot be measured directly. Instead, the angular alteration which occurs when the wheel is turned from 20° outwards to 20° inwards is measured on the instrument.

Most types of modern wheel alignment measuring instruments require that the wheels are locked with, for example, the help of a pedal jack. This is not sufficient on cars with Duo-servo brakes, since the brake shoes in this system have a certain amount of reciprocating travel. On such cars, therefore, the brake drum must be locked mechanically to the brake backing plate when measuring. This can be done by applying welding pliers between the drum and brake backing plate on each front wheel (see Fig. 4), when it is not necessary to use a pedal jack.

When measuring wheel alignment, follow the instructions applying for the measuring instruments concerned.

### Checks to be carried out before adjusting

Before any adjusting is carried out, the following points should be checked and any defects remedied.

1. Check the air pressure in all the tyres.
2. Check that the front wheel tyres are evenly worn. If not, replace them with the rear wheels or the spare wheel.
3. Check that the wheels are not warped more than 2.5 mm (0.1") and that the radial throw does not exceed 2.5 mm (0.1").
4. Check the front wheel bearings and king pin with bushes as well as shock absorbers.
5. Check that the wishbones are undamaged and firmly attached to the front axle member. Check that there is no excessive play in the wishbone bushes.
6. Check that the springs are undamaged and are not fatigued.
7. Check the clearance and adjustment of the steering box. With the steering box in the central position, the wheels should point straight forwards.
8. Check the steering rod, steering arms, idler arm and tie-rod.
9. Ensure that the car has normal equipment (oil, water, petrol and tools), but is otherwise unloaded.

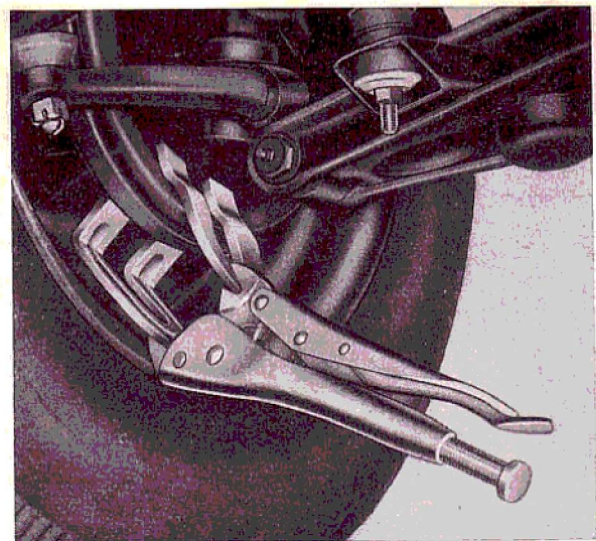

Fig. 4. Locking the brake drum.

**NOTE.** The front wheel alignment must always be adjusted in the following order:

1. Caster.
2. Camber.
3. Toe-out.
4. Toe-in.

### Adjusting the caster

On P 120 up to chassis number 2610 the caster should be  $0 \pm \frac{1}{2}^\circ$ . On P 120 with effect from chassis number 2611 and on all P 1800 the caster should be 0 to  $\pm 1^\circ$ . If it is the same on both sides, but incorrect, this is adjusted by means of shims (2, Fig. 5) between the front axle member and side member. When adjusting, the front end is lifted and blocks placed under the body at the jacking points. After the front axle member attaching bolts (1, 3 and 4, Fig. 5) have been slackened, the requisite number of adjusting shims are added or removed in order to obtain the correct caster. The attaching bolts must be tightened before a new measurement is made.

Shims for adjusting the caster at the front axle member — side member are available in thicknesses of 2 and 3 mm (0.079 and 0.118"). The extent to which caster is altered by these shims is shown in the diagram, Fig. 7. **N.B.** The alterations must be the same on both sides in order to avoid extra stress in the front axle member.

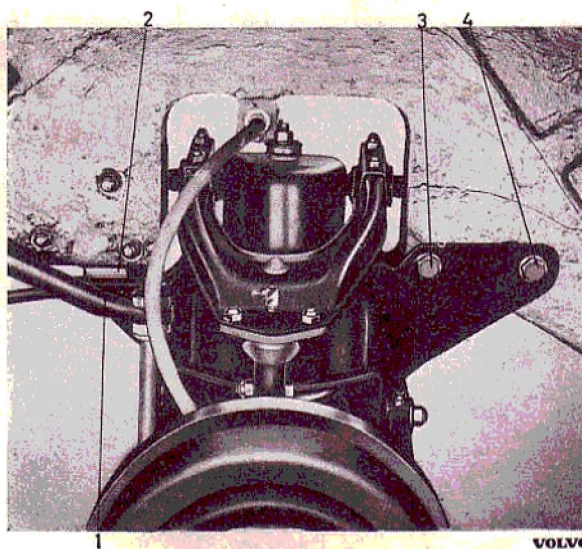

Fig. 5. Adjusting the caster.

- |          |         |
|----------|---------|
| 1. Bolt  | 3. Bolt |
| 2. Shims | 4. Bolt |

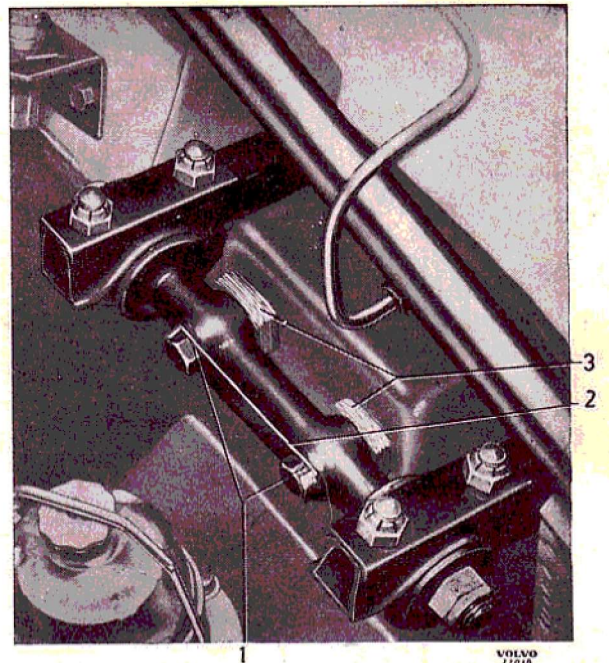

Fig. 6. Adjusting the camber and caster.

- |                  |
|------------------|
| 1. Bolts         |
| 2. Locking plate |
| 3. Shims         |

When the caster on the right and left sides is different, adjustment is done at the upper wishbone shaft, see Fig. 6.

Slacken the attaching bolt (1) so that the adjusting shims can be lifted up. These are stocked in thicknesses of 0.15, 0.5, 1, 3 and 6 mm (0.006, 0.012, 0.039, 0.018 and 0.236"). The extent to which these alter the caster is shown in the diagram, Fig. 7. The same alteration is obtained if a shim is removed from one of the attaching bolts or if it is added to the other. In both cases the camber is altered slightly and the procedure will therefore partly depend on how much it is required to alter this. **When the camber is correct, caster is adjusted by removing shims.** Always tighten the attaching bolts to a torque of 4.8–5.5 kgm (35–40 ft.lb.) before making a new measurement. When the correct caster has been obtained, the attaching bolts are locked with the locking plate (2, Fig. 6).

### Adjusting the camber

The camber should be 0 to  $+\frac{1}{2}^\circ$  and is adjusted by means of shims (3, Fig. 6) at the upper wishbone shaft. When doing this, the attaching bolts (1)

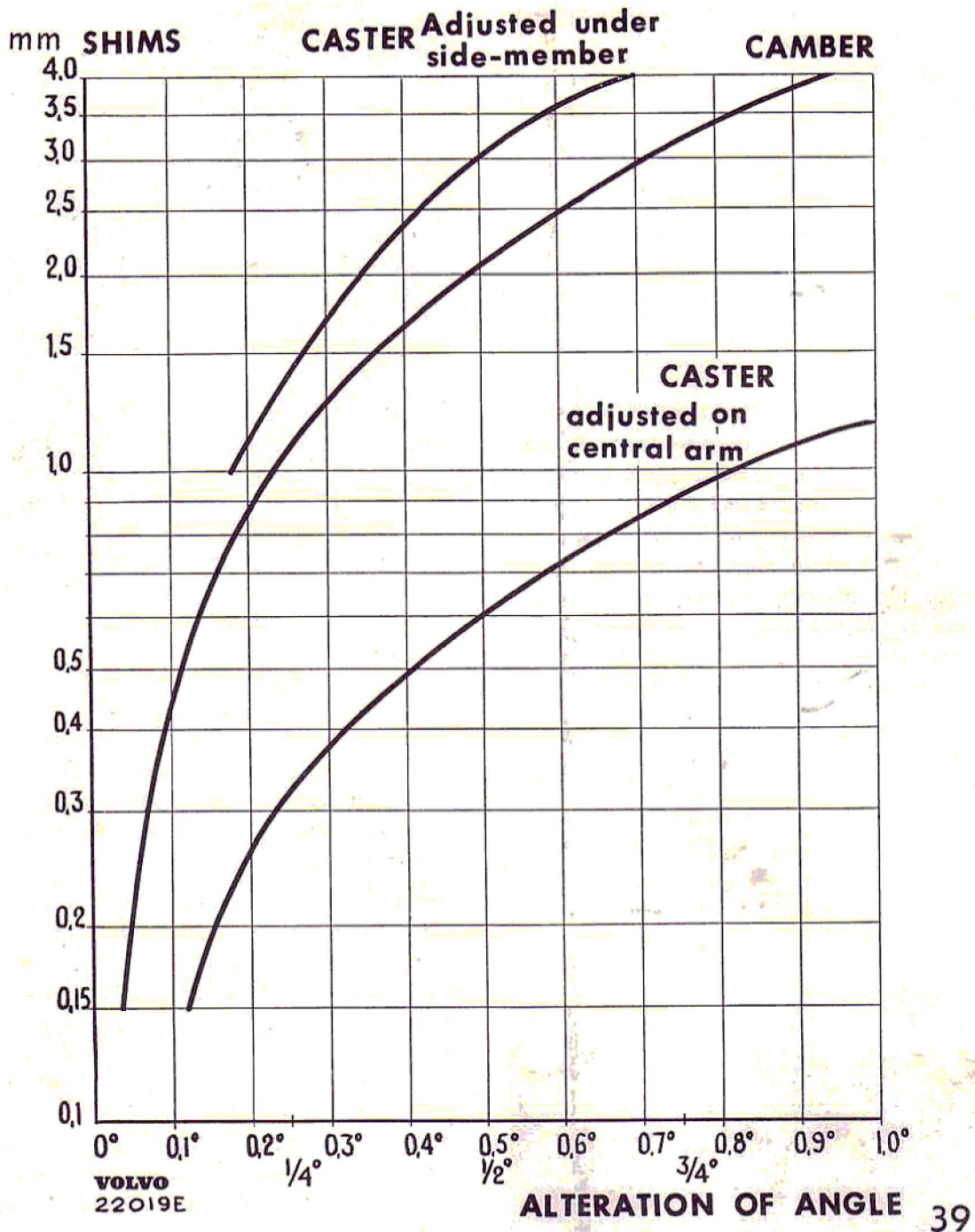

Fig. 7. Diagram for alteration of camber and caster.

are slackened slightly. The number of shims is increased or reduced depending on the angular error. After adjusting, the attaching bolts are tightened to a torque of 4.8–5.5 kgm (35–40 lb.ft.) and the camber checked.

Shims are stocked in the following thicknesses: 0.15, 0.5, 1, 3 and 6 mm (0.006, 0.012, 0.039, 0.018 and 0.236"). The extent to which the shims alter the angle can be seen from the diagram, Fig. 7.

**N.B.** Adjusting shims of the same thickness must be removed or added to both the attaching bolts as otherwise the caster will be altered.

When the correct camber has been obtained, the attaching bolts are locked with the locking plate (2, Fig. 6).

### Checking the king pin inclination

The king pin inclination, which on these vehicles is represented by the inclination of the centre line of the ball joints, should be  $8^\circ$  at a camber of  $0^\circ$ . This cannot be adjusted but can be used for checking any deformation on the stub axle.

### Checking the toe-out

1. Place the front wheels of the car on turntables and ensure that the wheels point straight forwards. Before the car is placed on

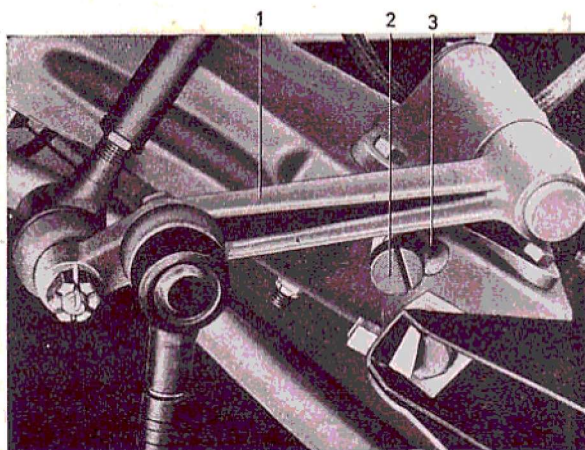

Fig. 8. Adjusting the steering limits.

1. Relay arm
2. Eccentric screw
3. Locknut

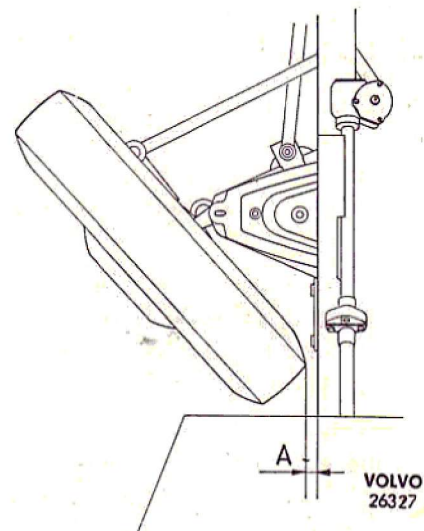

Fig. 9. Adjusting the wheel lock.

them, the turntables must be set to 0 and locked.

2. Turn the wheels to the left until the right wheel has turned  $20^\circ$  inwards. The scale on the left turntable should then read  $22.5 \pm 1^\circ$ .
3. Check the position of the right wheel in the same manner by turning the wheels to the right until the left wheel has turned  $20^\circ$  inwards, when the right turntable scale should give the same reading as previously indicated on the left. Both the measurements should thus lie within the above-mentioned tolerance, otherwise it means that the steering gear or front end is distorted.
4. There are no adjusting possibilities but if the toe-out is incorrect, the steering arms and steering rod should be checked. Any damaged parts should be replaced.

### Adjusting the toe-in

The toe-in should be 0–4 mm (0–5/32"). Incorrect toe-in is adjusted by slackening the clamping screws or locknuts respectively on the tie rod, after which the rod is turned in the required direction. The distance between the tyres at the front is reduced, that is to say, toe-in is increased, by turning the tie rod in the normal direction of rotation of the wheels.

### Adjusting steering limits (early production)

It should be possible to turn the wheels a maximum of  $40^\circ$  in either direction. Turning is limited by a stop screw on the pitman arm and relay arm, see Fig. 8. Adjustment is carried out as follows.

1. Set the front wheels to point straight forwards and drive them up on to turntables. When doing this, the turntables should be set to 0 and locked.
2. Release the turntable locking devices and turn the left wheel for a left-hand turn as far as it goes. Read off the turning angle. If this deviates from  $38-40^\circ$ , slacken the locknut for the eccentric head stop screw on the pitman arm. Turn the wheel to  $40^\circ$ . Adjust the stop screw so that it just contacts the pitman arm and tighten the locknut.
3. Repeat this procedure with the right wheel and stop screw on the relay arm.

### Adjusting steering limits (late production)

Turning is limited by the stop screw on the pitman arm and relay arm, see Fig. 9.

Adjusting is done as follows:

1. Turn the left wheel for a left-hand turn as far as it goes. Check that the distance between the tyre and the stabilizer (measurement A, Fig. 9) is 10–15 mm ( $25/64-19/32''$ ). If not, slacken the locknut for the relay arm stop screw, after which this is turned until the correct value is obtained. Then lock the stop screw.
2. Repeat this procedure with the right wheel and the stop screw on the pitman arm.  
**N.B.** Check that the brake hoses are clear at full wheel lock.

## GROUP 62

# FRONT AXLE DESCRIPTION

The P 120 and P 1800 have independent front wheel suspension. This means that there is no actual front axle, this being replaced by a robust box-section front axle member. This member is bolted to the self-supporting body and the front wheel suspension and springs are fitted at the ends of the member. The construction is illustrated in Fig. 10.

The steering knuckle is pivoted on the upper and lower wishbones by means of ball joints. At the inner attachments of the wishbones the move-

ment is transmitted through rubber bushes, see Figs. 11 and 12. Camber and caster are adjusted by means of shims on the upper wishbone shaft and front axle member and side member respectively.

The front wheels are carried in taper roller bearings. The front suspension consists of coil springs inside which telescopic shock absorbers are fitted. In order to increase anti-rolling properties, the car is equipped with a stabilizer which is attached to both the lower wishbones and to the body.

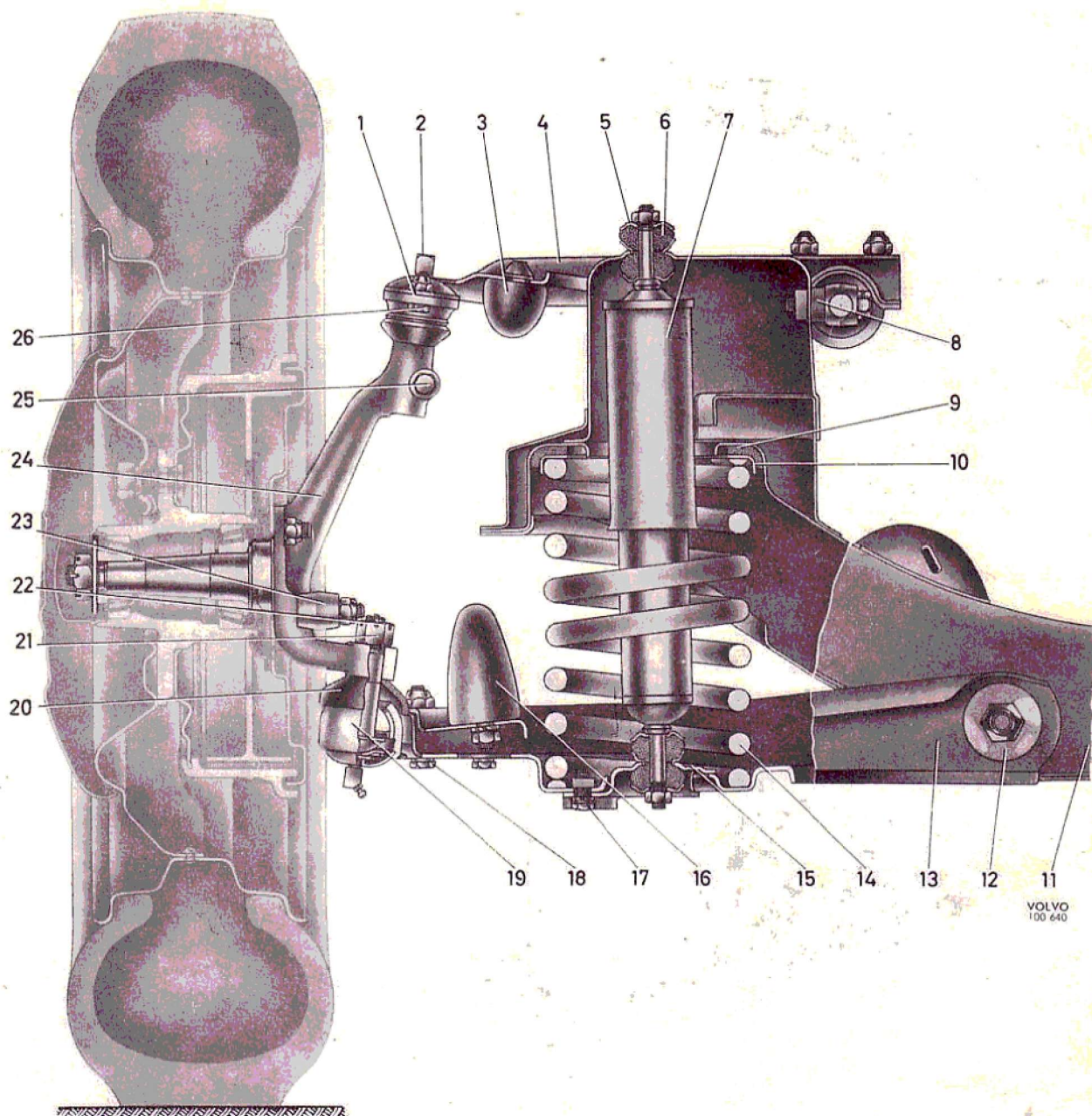
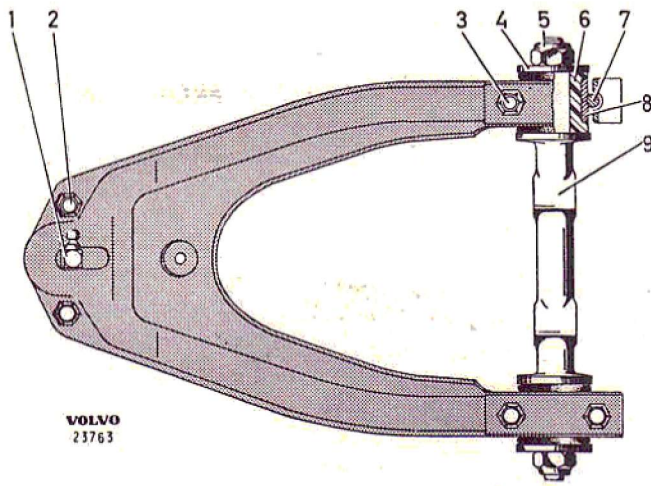

Fig. 10. Front axle.

- |                     |                       |                      |
|---------------------|-----------------------|----------------------|
| 1. Upper ball joint | 10. Washer            | 19. Lower ball joint |
| 2. Grease nipple    | 11. Front axle member | 20. Rubber cover     |
| 3. Rubber buffer    | 12. Washer            | 21. Nut              |
| 4. Upper wishbone   | 13. Lower wishbone    | 22. Split pin        |
| 5. Washer           | 14. Front spring      | 23. Steering arm     |
| 6. Rubber bush      | 15. Retaining washer  | 24. Steering knuckle |
| 7. Shock absorber   | 16. Rubber buffer     | 25. Clamping bolt    |
| 8. Shims            | 17. Bolt              | 26. Bolt             |
| 9. Rubber insert    | 18. Bolt              |                      |



VOLVO  
23763

Fig. 11. Upper wishbone.

1. Grease nipple
2. Attaching nut for ball joint
3. Nut for clamp
4. Flat washer
5. Nut
6. Rubber bush
7. Clamp
8. Sleeve
9. Upper wishbone shaft

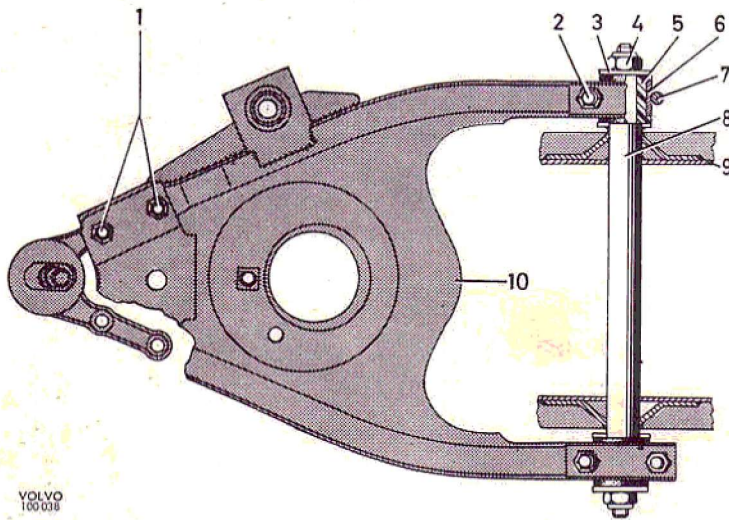

VOLVO  
100 038

Early production

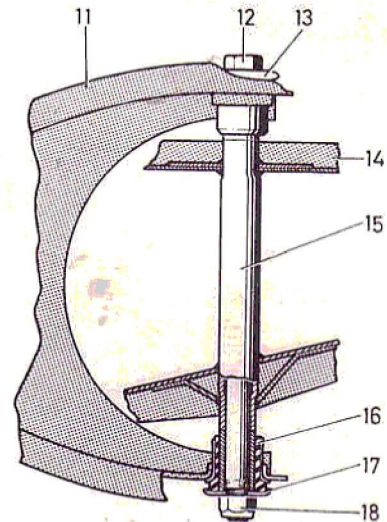

Late production

Fig. 12. Lower wishbone.

- |                                  |                             |
|----------------------------------|-----------------------------|
| 1. Attaching nuts for ball joint | 11. Wishbone                |
| 2. Nut for clamp                 | 12. Bolt                    |
| 3. Flat washer                   | 13. Washer 14.5 mm diameter |
| 4. Nut                           | 14. Front axle member       |
| 5. Rubber bush                   | 15. Pipe (welded on)        |
| 6. Sleeve                        | 16. Bush                    |
| 7. Clamp                         | 17. Washer 19.5 mm diameter |
| 8. Lower wishbone shaft          | 18. Nut                     |
| 9. Front axle member             |                             |
| 10. Lower wishbone               |                             |

## REPAIR INSTRUCTIONS

### REMOVING THE COMPLETE FRONT END

1. Remove the hub caps and slacken the wheel nuts.
2. Jack up the front end so that the wheels are clear of the ground. Place blocks under the body at the front jacking points.
3. Remove the wheel nuts and lift off the wheels.
4. Place a support under the front part of the engine.
5. Place a wooden block under the brake pedal. Disconnect the brake hoses from the body and plug the connections so that no dirt can enter.
6. Remove the pitman arm with the help of puller SVO 2282. See Fig. 13.
7. Disconnect the front engine mountings. Disconnect the relay arm and stabilizer from the body.
8. Place a jack under the front axle member. Screw out the front axle member attaching bolts (1, 3 and 4, Fig. 5). Take care of the shims (2).
9. Lower the front axle member and pull it out.

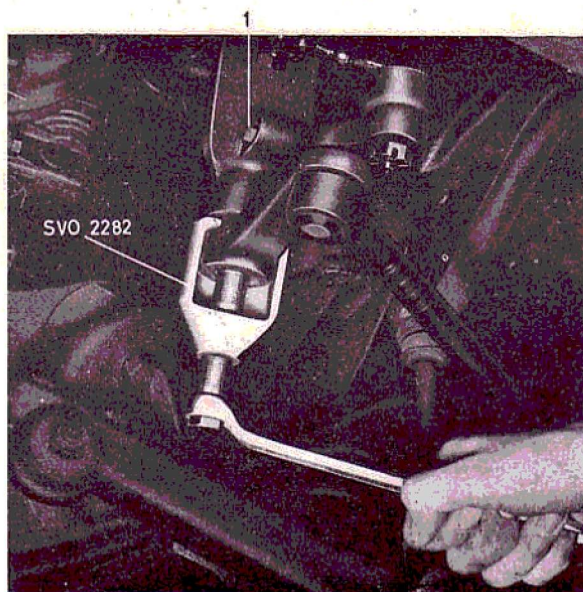
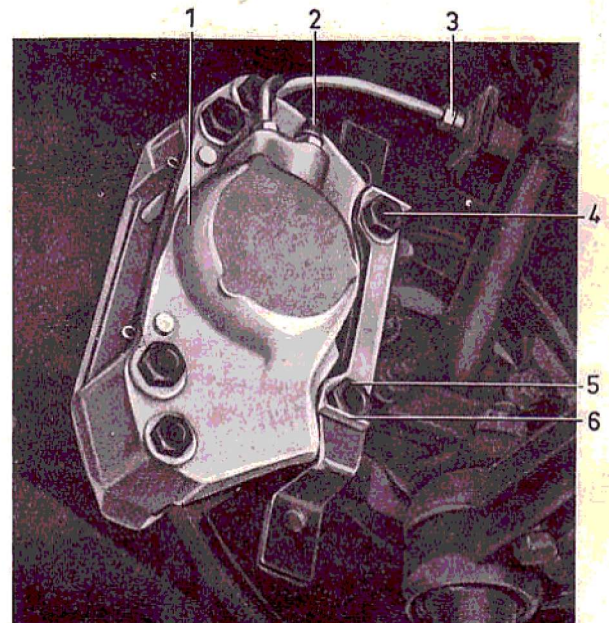

Fig. 13. Removing the pitman arm.

### FITTING THE COMPLETE FRONT END

1. Place the front axle member on a jack and move it under the vehicle.
2. Raise the jack so that the member comes in the right position. Place in the shims and tighten the bolts (1, 3 and 4, Fig. 5) well.
3. Remove the support under the engine and tighten down the engine onto the front mountings.
4. Fit the relay arm and stabilizer to the body.
5. Fit the pitman arm, when the line-up marks on the pitman arm shaft and pitman arm should coincide. Fit the spring washer and nut. Tighten the nut to a torque of 13.5–16.5 kgm (100–200 lb.ft.).
6. Connect the brake lines and air-vent the brake system (see Part 5, Brakes).
7. Fit the wheels and lower the vehicle. Tighten the wheel nuts to a torque of 10–14 kgm (70–100 lb.ft.). Fit the hub caps.
8. Check the wheel alignment. See "Wheel Alignment", page 6–2.



VOLVO  
26928

Fig. 14. Front wheel brake unit.

- |                       |                   |
|-----------------------|-------------------|
| 1. Caliper            | 4. Attaching bolt |
| 2. Air-venting nipple | 5. Attaching bolt |
| 3. Brake line         | 6. Locking plate  |

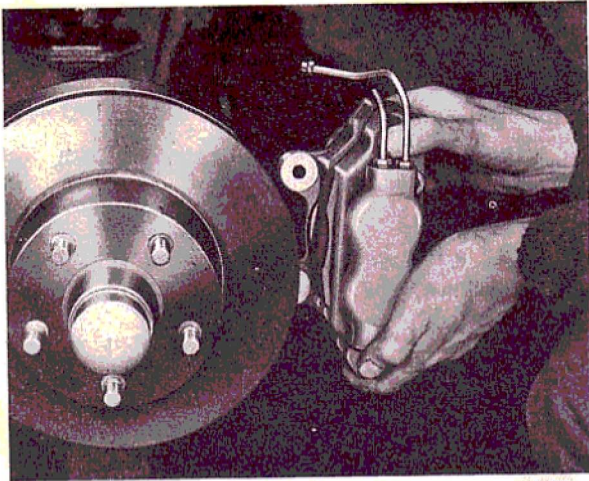

VOLVO  
26929

Fig. 15. Removing the front wheel brake unit.

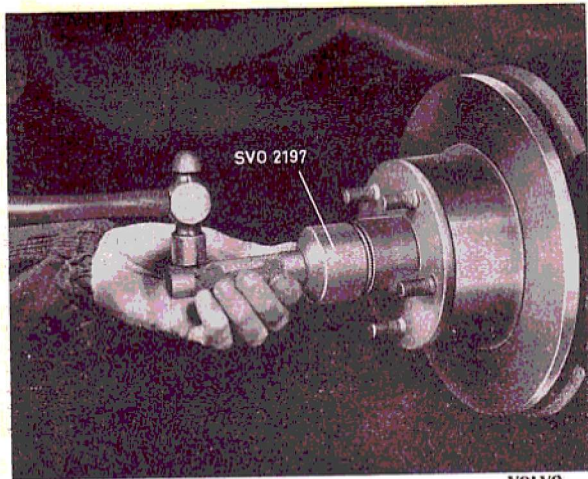

VOLVO  
24558

Fig. 16. Removing the grease cap.

### REPLACING THE STUB AXLE

1. Remove the hub cap and slacken the wheel nuts slightly.
2. Jack up the front end and place blocks under the lower wishbones. Screw off the wheel nuts and lift down the wheel.
3. (Only applies to vehicles with disc brakes.) Disconnect the brake line (3, Fig. 14) and plug the connection. Bend back the locking plate (6), and unscrew the attaching bolts (4 and 5). Lift off the caliper (1) complete, see Fig. 15.
4. Remove the grease cap with tool SVO 2197, see Fig. 16. Remove the split pin and castle nut. Pull off the hub with puller SVO 1791, see Fig. 17. Pull off the inner bearing from the stub axle with puller SVO 1794, see Fig. 18, if the bearing remains in position.
5. Remove the ball joints in accordance with the instructions on page 6-11, "Replacing the upper and lower ball joints".
6. Replace the stub axle and fit the ball joints in the reverse order.
7. Place the inner bearing in position in the hub. Press in the oil seal with drift SVO 1798 and standard handle SVO 1801, see Fig. 19.
8. Place the hub on the stub axle. Fit the outer bearing, washer and castle nut.
9. The front wheel bearings are adjusted by first tightening the nut with a torque wrench

10. Fill the grease cap half full of grease and fit it with tool SVO 2197.
11. (Only applies to vehicles with disc brakes.) Fit the caliper and lock the attaching bolts.

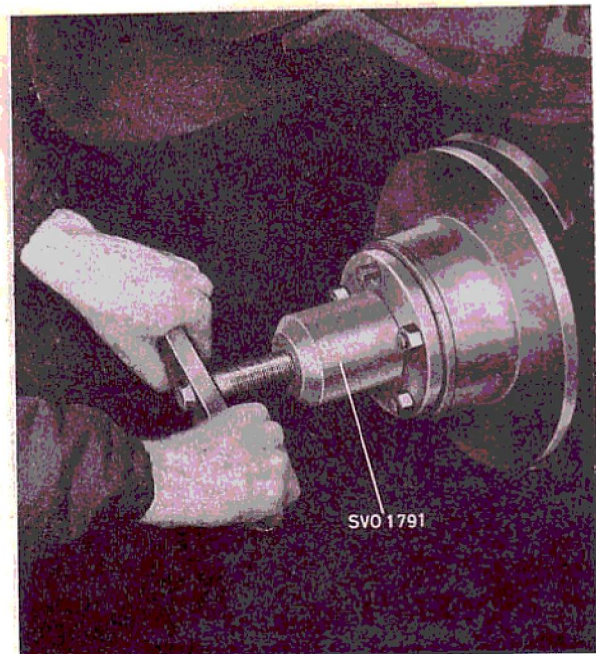

VOLVO  
24559

Fig. 17. Removing the hub.

Connect the brake line. Air-vent the wheel unit cylinders, see Part 5.

12. Lift on the wheel after having cleaned the contact surfaces between the wheel and hub free from sand and dirt, and then tighten the nut sufficiently so that the wheel cannot be displaced on the hub. Lower the vehicle and tighten the wheel nuts finally. Tighten every other nut at a time until all of them are tightened to a torque of 10–14 kgm (70–100 lb.ft.). Fit the hub cap.

## RECONDITIONING THE WISHBONE SYSTEM

The ball joints cannot be dismantled or adjusted, so that when worn they must be replaced.

The wishbone may only be straightened to a minor extent and then only in a cold condition. If the old part deviates to any great extent when compared with a new one, it should be replaced.

### Replacing the upper ball joint

On about 5000 P 120 cars within chassis numbers 58818–71000, ball joints without grease nipples can be fitted. Such ball joints do not need lubricating. However, the rubber seal should be inspected about once a year and replaced in the event of damage. When fitting a new rubber seal, it should be filled with chassis grease.



VOLVO  
24560

Fig. 18. Removing the inner bearing.

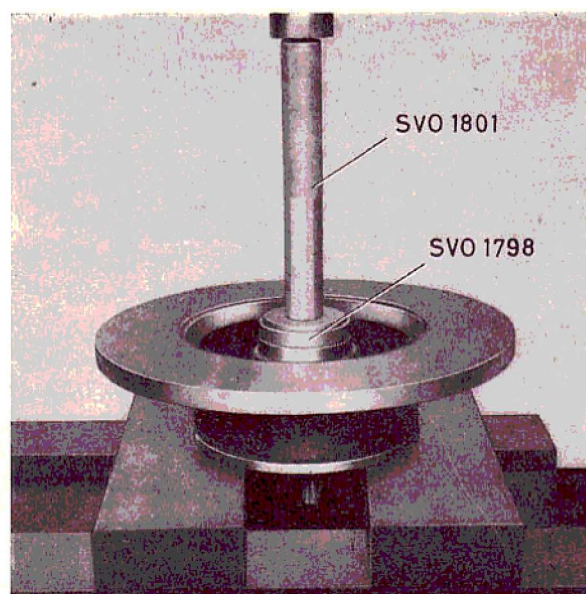

VOLVO  
24561

Fig. 19. Fitting the oil seal.

When replacing a ball joint with grease nipple, the rubber seal and washer belonging to it must also be fitted.

1. Remove the hub cap and slacken the wheel nuts slightly.
2. Jack up the front end and place a block under the lower wishbone. Screw off the wheel nuts and lift down the wheel.
3. Screw off the nuts and remove the bolts (26, Fig. 10). Lift off the upper wishbone (4).
4. Screw off the nut and remove the bolt (25). Remove the upper ball joint (1) with sealing washer and rubber cover from the stub axle.
5. Fitting is done in the reverse order. Fill chassis grease between the rubber cover and ball joint.

On P 120 with chassis numbers lower than 84300, a special ball joint can be fitted, the purpose of which is to increase the adjusting range of the front wheel alignment. In cases where this ball joint is fitted, the attaching holes of which are moved 2.5 mm (0.10") in relation to the ball stud, 2.5 mm (0.10") washers should be placed between the ball joint and wishbone and longer attaching bolts used (7/8").

### Replacing the lower ball joint

No lubrication is required on ball joints without grease nipples. However, the rubber seals of the

ball joints should be inspected and replaced if necessary about once a year. When fitting a new rubber seal, this should be filled with chassis grease.

On ball joints without grease nipples, the ball stud has a 1/2"-20 UNF thread compared with an M 12 X 1.5 thread for ball joints with grease nipples. Therefore make sure that the correct nut is used when replacing a ball joint.

1. Remove the hub cap and slacken the wheel nuts slightly.
2. Jack up the front end and place a block under the lower wishbone. Unscrew the wheel nuts and lift off the wheel.
3. Unscrew the nuts and remove the four bolts (18, Fig. 10). Remove the split pin (22) and nut (21).

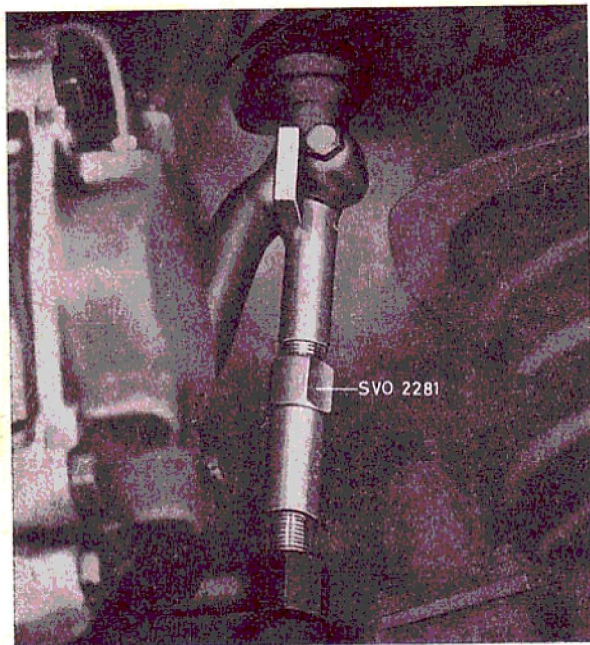

Fig. 20. Removing the lower ball joint.

4. On vehicles with disc brakes, disconnect the brake line from the retainer. Fit tool SVO 2281 on the stub axle as shown in Fig. 20. It may be necessary to bend the retainer for the brake line slightly to one side. Turn the nut on the tool until the tool begins to tension. Then turn the nut until the ball joint releases, but no more than 1 1/2 turns. If the ball joint does not release at this stage, strike a few light blows on the stub axle

ball joint attachment with a hammer and dolly.

5. Fitting is done in the reverse order. The castle nut is tightened to a torque of 4.8-5.5 kgm (35-40 lb.ft.). Fill grease between the rubber protector and ball joint. Air-vent the wheel unit cylinders in cases where the brake line has been removed.

### Replacing the upper wishbone bushes

1. Remove the hub cap and slacken the wheel nuts slightly.
2. Jack up the front end and place a block under the lower wishbone. Unscrew the wheel nuts and lift off the wheel.
3. Screw off the nuts (3, Fig. 11) and remove the clamps (7).
4. Bend back the locking washer, screw out the attaching bolts and remove the shaft (9). Take care of the shims.
5. Remove the nuts (5), washers (4) and bushes (6) with sleeves (8).
6. Fit the new rubber bushes (6) and sleeves (8) on to the wishbone shaft (9).

In order to facilitate fitting it is advisable to use soap solution as lubricant.

Fit the washers (4) and tighten the nuts (5). Then attach the wishbone with clamps loosely on the two bushes.

7. Fit the shims and secure the shaft (9) and wishbone. Tighten the attaching bolts (1, Fig. 6) to a torque of 4.8-5.5 kgm (35-40 lb.ft.) and lock them with the tabs on the locking plate (2).
8. Tighten the attaching nuts (3, Fig. 11) for the clamps to a torque of 2-2.5 kgm (14-18 lb.ft.). Fit the other parts in the reverse order to removing.
9. Check the wheel alignment, see under "Wheel Alignment".

### Replacing the upper wishbone

1. Remove the hub cap and slacken the wheel nuts slightly.
2. Jack up the front end and place a block under the lower wishbone. Unscrew the wheel nuts and lift off the wheel.
3. Screw off the nuts (3, Fig. 11) and remove the clamps (7).

4. Remove the nuts (2) and attaching bolts for the upper ball joint and lift off the upper wishbone.
5. Fitting is done in the reverse order to removing. Tighten the nuts (3, Fig. 11) for the clamps to a torque of 2–2.5 kgm (14–18 lb.ft.). Check the wheel alignment, see under "Wheel Alignment".

### Replacing the lower wishbone bushes

#### Early production

1. Jack up the front end and place blocks under the front axle member.
2. Unscrew the nuts (2, Fig. 12) and remove the clamps (7). Remove the nuts (4) and washers (3).
3. Place a jack under the lower wishbone inside the spring and lift so that the bushes are unloaded. Pull off the bushes (5) and sleeves (6).
4. Coat the rubber bushes (5) and sleeves (6) with soap solution and fit them onto the wishbone shaft (8). Fit the washers (3) and nuts (4).

When tightening the nuts, the outer part of the wishbone should be lifted so that the distance between the rubber buffer (16, Fig. 10) and the front axle member is about 40 mm (1 9/16").

5. Lower the wishbone and fit the clamps (7, Fig. 12) and nuts (2). Tighten the nuts to a torque of 2–2.5 kgm (14–18 lb.ft.).
6. Lower the vehicle. Check the wheel alignment, see under "Wheel Alignment".

#### Late production

1. Jack up the front end and place blocks under the front axle member.
2. Unscrew the nut (18, Fig. 12). Use a spanner on the bolt head as a counterhold if the bolt (12) turns. Remove the washer (17).
3. Place a jack under the lower wishbone inside the spring and lift so that the bolt can be withdrawn easily.
4. Then replace the old bushes (16) with new ones and make sure that they are turned correctly.
5. Fit the bolt (12). Make sure that the smallest washer (13) is placed nearest to the bolt head.
6. Place on the large washer (17) and nut (18), which must not be tightened.

7. Lower the jack and place it under the wishbone at the outer edge of the spring. Lift carefully until the distance between the top of the rubber buffer (16, Fig. 10) and the front axle member (11) is about 40 mm (1 9/16"). Tighten the nut (18, Fig. 12) in this position.
8. Lower the vehicle. Check the wheel alignment, see under "Wheel Alignment".

### Replacing the lower wishbone

1. Remove the hub cap and slacken the wheel nuts slightly.
2. Jack up the front end and place blocks under the front axle member. Unscrew the wheel nuts and lift off the wheel.
3. Remove the upper nut for the shock absorber (Fig. 10), washer (5) and rubber bushes (6). Remove the bolt (17) for the retaining washer (15). Remove the washer and shock absorber (7) downwards.
4. Place a jack under the lower wishbone centrally under the spring. Raise the jack until the upper wishbone rubber buffer (3) lifts.
5. Disconnect the stabilizer from the lower wishbone. Remove the four attaching bolts (18) and disconnect the lower ball joint from the wishbone.
6. Lower the jack slowly and remove the spring (14) when the wishbone has come sufficiently far down.
7. Early production. Remove the nuts and clamps on the inner attachment, after which the wishbone can be lifted off.

Late production. Unscrew the nut (18, Fig. 12) and remove the washer (17). Pull out the bolt (12), after which the wishbone can be lifted off. Take care of the bushes and washers.

8. Fitting is done in the reverse order. On early production, the nuts (2, Fig. 12) for the clamps are tightened to a torque of 2.0–2.5 kgm (14–18 lb.ft.).

On both types, the distance between the top of the rubber buffer (16, Fig. 10) and the front axle member (11) should be about 40 mm (1 9/16") when tightening the nuts (2, Fig. 12) and nut (18) for the wishbone inner attachment. After fitting, check and if necessary adjust the wheel alignment, see under "Wheel Alignment".

GROUP 64

# STEERING GEAR DESCRIPTION

The design of the steering gear on P 120 is illustrated in Figs. 21, 22, 24-26 and on P 1800 in Figs. 21, 23, 25 and 26.

The movement of the steering wheel is transmitted to the road wheels via the steering column (2, Fig. 22), steering box (8), pitman arm (11), tie rod (12), relay arm (15), steering rods (7 and 17) and steering arms (5 and 18).

The steering box (Fig. 21) is of the "cam and roller" type.

On early production, the relay arm (Figs. 24 and 25) is mounted in needle bearings and in late

production (Fig. 26) in bushes. The steering column is divided into two parts (2 and 6, Fig. 22) which are jointed with a coupling (3). The upper section of the steering column is carried in bearings in the jacket tube. The steering rod ball joints are plastic-lined which means that they do not require lubricating.

The car has a turning circle of about 9.5 metres (32 ft.).

The number of steering wheel turns from lock to lock is 3 1/4.

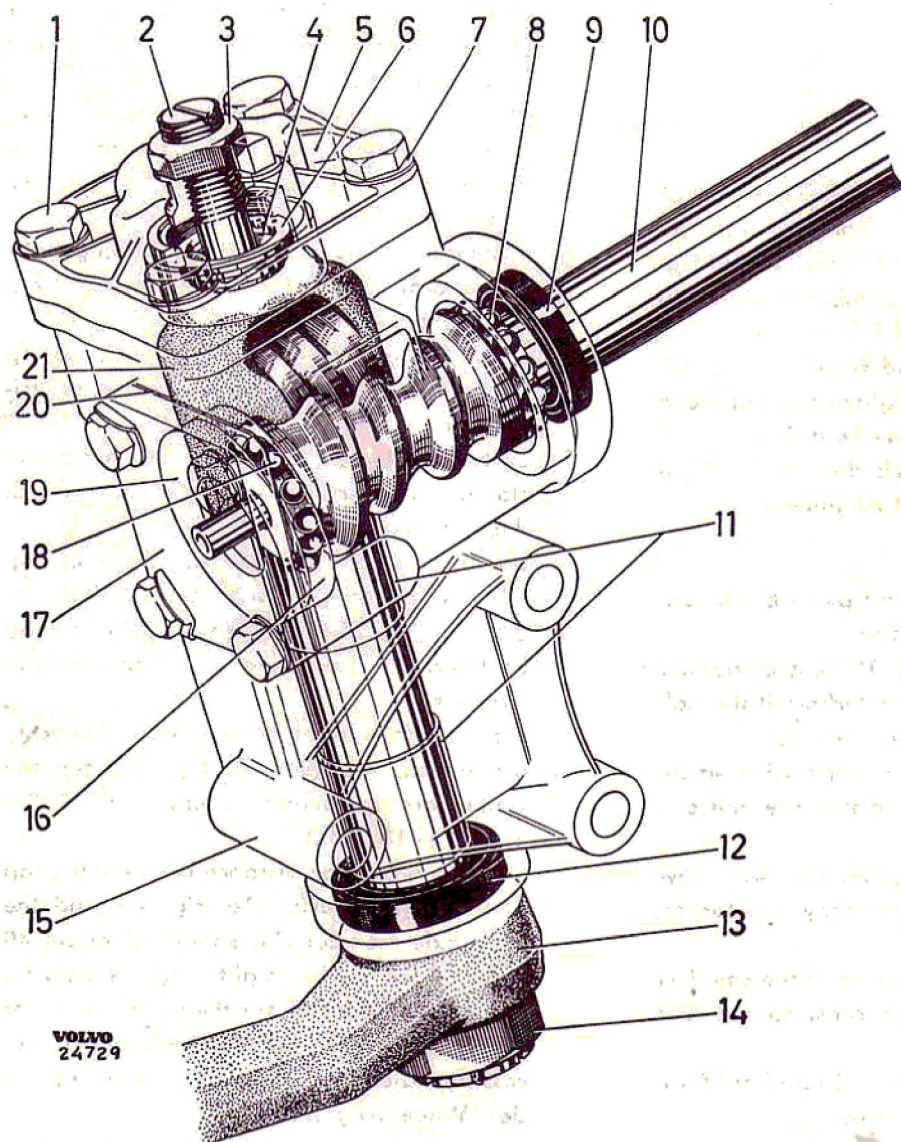

Fig. 21. Steering box.

- 1. Bolt
- 2. Adjusting screw
- 3. Locknut
- 4. Pitman arm shaft bush
- 5. Cover
- 6. Circlip
- 7. Tab washer
- 8. Steering column bearing, upper
- 9. Steering column oil seal
- 10. Steering column
- 11. Pitman arm shaft bush
- 12. Pitman arm shaft seal
- 13. Pitman arm
- 14. Nut
- 15. Steering box body
- 16. Steering column bearing shell, lower
- 17. Steering column cover
- 18. Steering column bearing, lower
- 19. Washer
- 20. Shims
- 21. Pitman arm shaft with roller

VOLVO  
24729

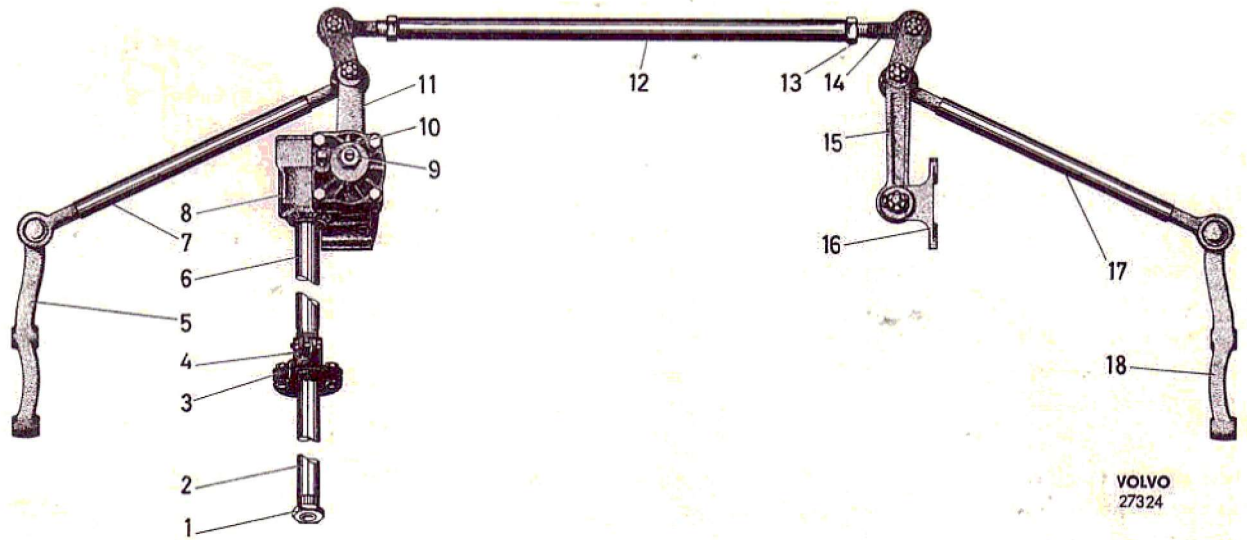

Fig. 22. Steering gear (late production) P 120.

- |                                   |                                   |  |                         |
|-----------------------------------|-----------------------------------|--|-------------------------|
| 1. Steering wheel nut             | 6. Steering column, lower section | 11. Pitman arm   | 15. Relay arm           |
| 2. Steering column, upper section | 7. Steering rod, left             | 12. Tie rod  | 16. Relay arm bracket   |
| 3. Coupling disc                  | 8. Steering box                   | 13. Locknut (late production Clamping bolt (early production)) | 17. Steering rod, right |
| 4. Clamp                          | 9. Adjusting screw                | 14. Tie rod end  | 18. Steering arm, right |
| 5. Steering arm, left             | 10. Oil filling plug              |  |                         |

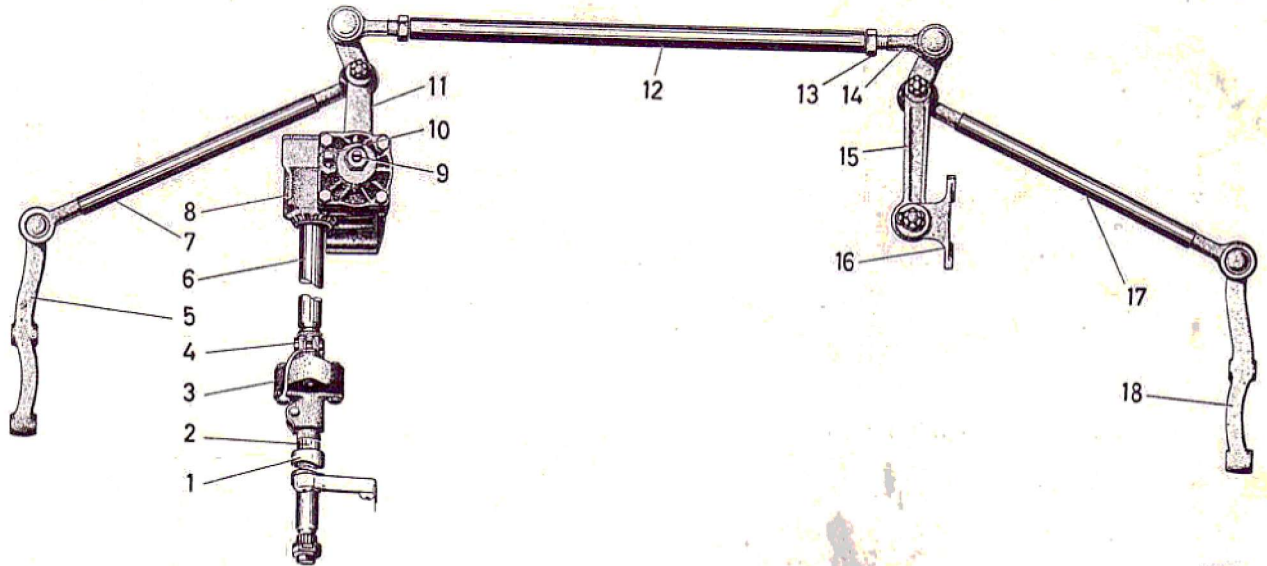

Fig. 23. Steering gear, P 1800.

- |                                   |                                   |                      |                         |
|-----------------------------------|-----------------------------------|----------------------|-------------------------|
| 1. Steering column jacket tube    | 5. Steering arm, left             | 10. Oil filling plug | 16. Bracket             |
| 2. Steering column, upper section | 6. Steering column, lower section | 11. Pitman arm       | 17. Steering rod, right |
| 3. Coupling                       | 7. Steering rod, left             | 12. Tie rod          | 18. Steering arm, right |
| 4. Clamp                          | 8. Steering box                   | 13. Locknut          |                         |
|                                   | 9. Adjusting screw                | 14. Ball joint       |                         |
|                                   |                                   | 15. Relay arm        |                         |

Fig. 24. Relay arm mounting, type I.

- 1. Split pin
- 2. Nut
- 3. Flat washer
- 4. Vulcollan washer
- 5. Relay arm bracket
- 6. Needle bearing
- 7. Adjusting washers
- 8. Vulcollan washer
- 9. Relay arm
- 10. Hole for steering rod

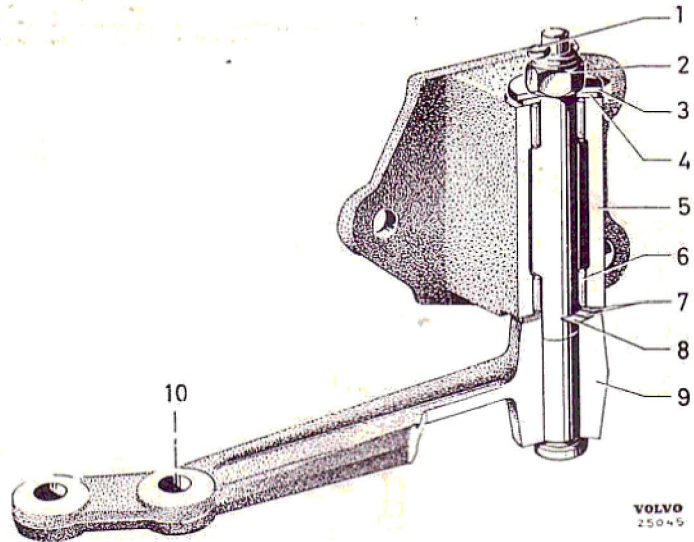

Fig. 25. Relay arm mounting, type II.

- 1. Split pin
- 2. Nut
- 3. Flat washer
- 4. Vulcollan washer
- 5. Shims
- 6. Bracket
- 7. Needle bearing
- 8. Oil seal
- 9. Vulcollan washer
- 10. Relay arm
- 11. Hole for steering rod

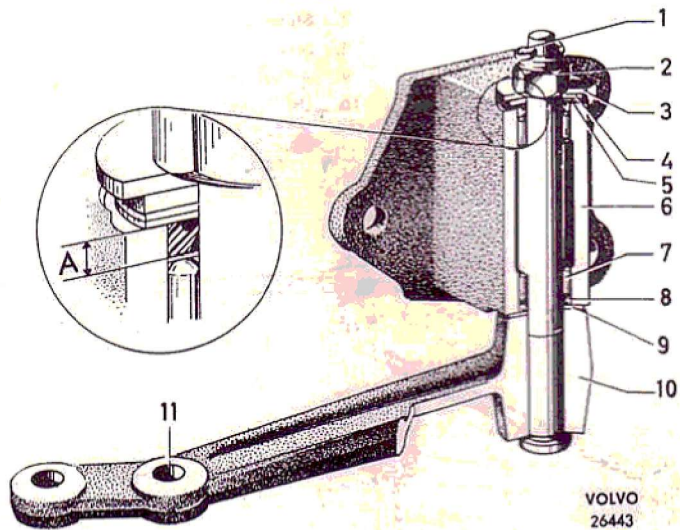
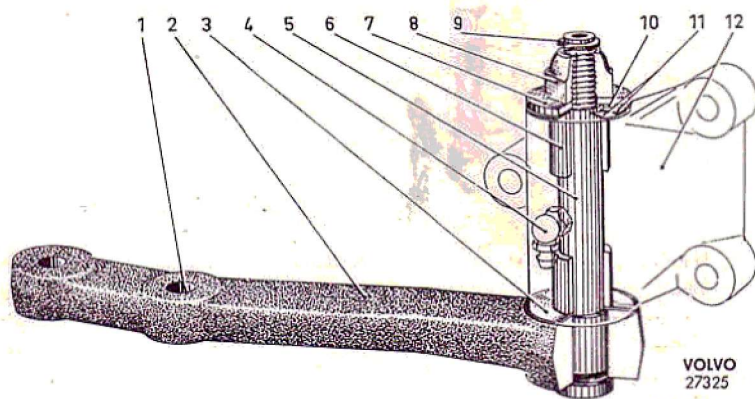

Fig. 26. Relay arm mounting, type III.

- 1. Hole for steering rod
- 2. Relay arm
- 3. Vulcollan washer
- 4. Grease nipple
- 5. Shaft
- 6. Bush
- 7. Washer
- 8. Nut
- 9. Circlip (late production only)
- 10. Vulcollan washer
- 11. Shims
- 12. Bracket



## REPAIR INSTRUCTIONS

**REPLACING THE STEERING WHEEL, P 120**

1. Unscrew both the attaching bolts on the underside of the steering wheel spokes and remove the horn ring upwards.
2. Bend up the locking washer and remove the steering wheel nut. Mark the position of the steering wheel.
3. Set the direction indicator switch in the neutral position. Pull off the steering wheel with puller SVO 2263. (Late production, SVO 2325, see "Tool List".)
4. Fit the new steering wheel, noting the line-up marks. The steering wheel spokes should be horizontal when the wheels are pointed straight forwards. Tighten the steering wheel nut to a torque of 3.5–5.0 kgm (25–35 lb.ft.) and then lock with the locking washer.
5. Fit the horn ring and check its function.

VOLVO  
400123

Fig. 27. Removing the steering wheel, P 120.

**REPLACING THE STEERING WHEEL, P 1800**

1. Pull out the horn lead from the connecting block on the steering box.
2. Carefully prise out the horn button with a screwdriver or similar, see Fig. 28.
3. Bend back the locking washer and remove the steering wheel nut. Mark the position of the steering wheel.
4. Pull off the steering wheel, see Fig. 29. Re-

VOLVO  
24563

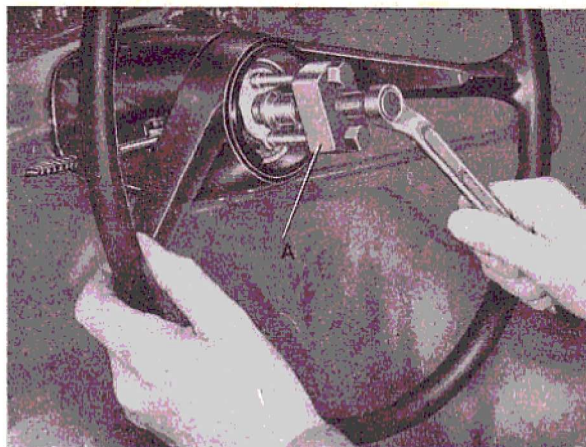
Fig. 28. Removing the horn button, P 1800.

move the housing and hub from the steering wheel.

5. Fit the new steering wheel and other parts in the reverse order, noting the line-up marks. Tighten the steering wheel nut to a torque of 3.5–5.0 kgm (25–35 lb.ft.) and then lock it.

VOLVO  
24564

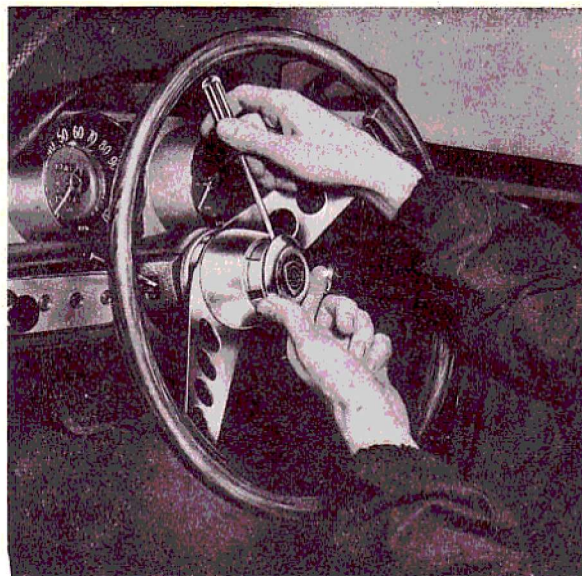
Fig. 29. Removing the steering wheel, P 1800.

### STEERING BOX

#### Removing, P 120

1. Disconnect the horn lead from the connecting block.
2. Unscrew the two nuts (2 and 4, Fig. 30) and remove the bolts.
3. Remove the pitman arm with puller SVO 2282, see Fig. 13.
4. Unscrew and remove the three attaching bolts (6, Fig. 30).
5. Lift and turn the steering box as shown in Fig. 31. Pull out the horn lead (3) from the lower section of the steering column and steering box. Lift off the steering box but be careful when moving the clamp (2) past the brake line (1).

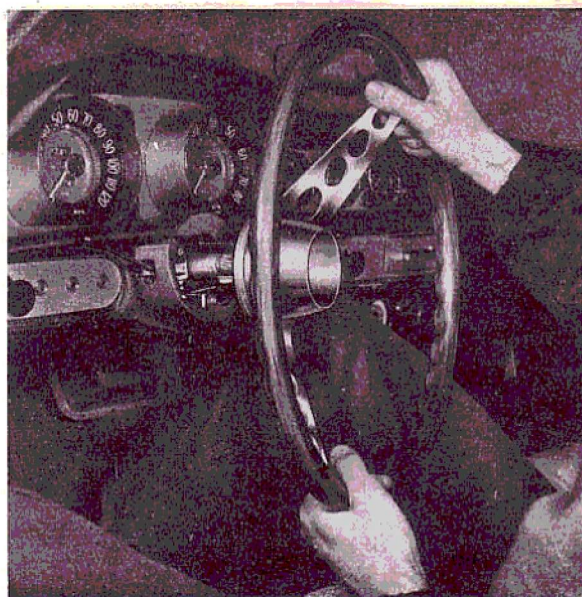
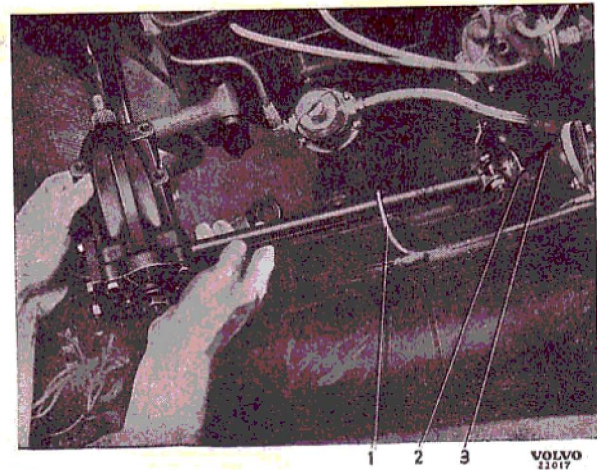

Fig. 31. Removing the steering box.

1. Brake line
2. Clamp
3. Horn lead

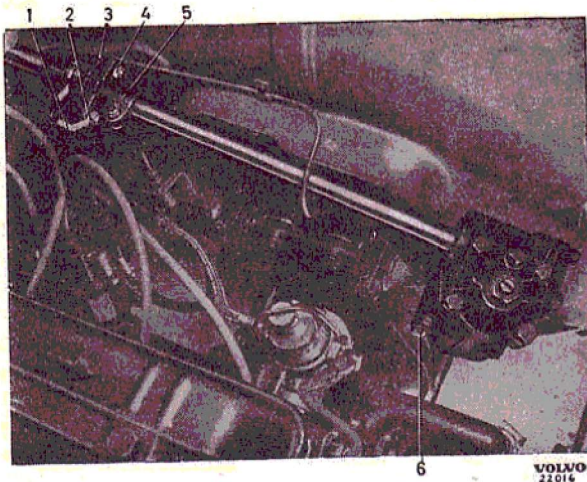

Fig. 30. Steering box.

- |                  |          |
|------------------|----------|
| 1. Earth lead    | 4. Nut   |
| 2. Nut           | 5. Clamp |
| 3. Coupling disc | 6. Bolt  |

#### Removing, P 1800

1. Pull out the horn lead from the connecting block on the steering box.
2. Disconnect the earth lead (8, Fig. 32) and unscrew the two nuts (4 and 7).
3. Remove the pitman arm with puller SVO 2282, see Fig. 13.

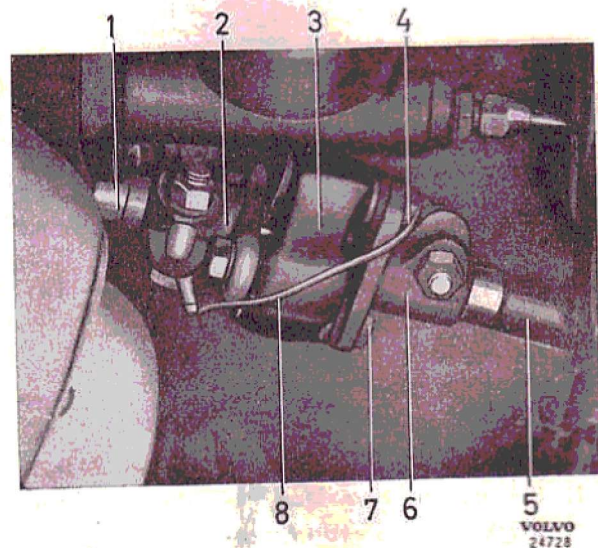

Fig. 32. Steering column coupling, P 1800.

- |                                   |                                   |
|-----------------------------------|-----------------------------------|
| 1. Steering column, upper section | 5. Steering column, lower section |
| 2. Clamp                          | 6. Clamp                          |
| 3. Coupling disc                  | 7. Nut                            |
| 4. Nut                            | 8. Earth lead                     |

VOLVO  
23758

Fig. 33. Removing the adjusting screw.

### Dismantling

1. Wash the steering box clean externally and remove the clamp (5, Fig. 30) from the steering column.
2. Remove the four bolts (1, Fig. 21) for the upper cover (5), pull up the cover and pitman arm shaft slightly and drain off the oil. Pull out the cover and pitman arm shaft.
3. Remove the bolts and lower cover (17). Take care of the shims (20).
4. Carefully knock the steering column (10) so that the outer race of the lower bearing releases from the housing. Take out the steering column (10) with bolt and bearing.
5. Slacken the locknut (3) and screw the adjusting screw (2) out of the cover. The adjusting screw can be removed from the pitman arm shaft after the circlip has been taken off, see Fig. 33.

### Inspecting

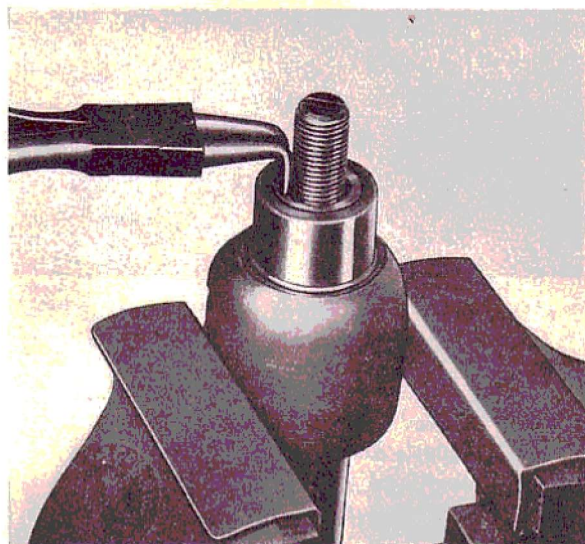
Clean all parts in white spirit or similar. Examine the oil seals. If these show the slightest signs of damage or wear, they must be replaced. Removing is done with the help of puller SVO 4030 or with a screwdriver. Check the pitman arm shaft. The roller must not be scratched, scored or noticeably worn on the contact surfaces or be loose in

the pitman arm shaft. If so, or if the pitman arm shaft is damaged in any other way, it must be replaced.

Examine the roller contact surfaces on the cam and the inner races of the ball bearings. If there are scratches, scoring or noticeable wear the cam with steering column must be replaced. Examine the outer rings and balls of the bearings. Any scored or otherwise damaged bearing parts must be replaced. The outer ring of the upper bearing is removed with puller SVO 1819 or, if the oil seal is removed, with drift SVO 1708.

Check to see whether the pitman arm shaft is loose in the bushes. If so, the bushes in the housing must be replaced, when they are removed in either direction with puller SVO 1819, see Fig. 34. The bush in the pitman arm shaft cover cannot be removed so that the complete cover must be replaced.

VOLVO  
23755

Fig. 34. Removing the pitman arm shaft bush.

1. SVO 1819
2. Pitman arm shaft bush

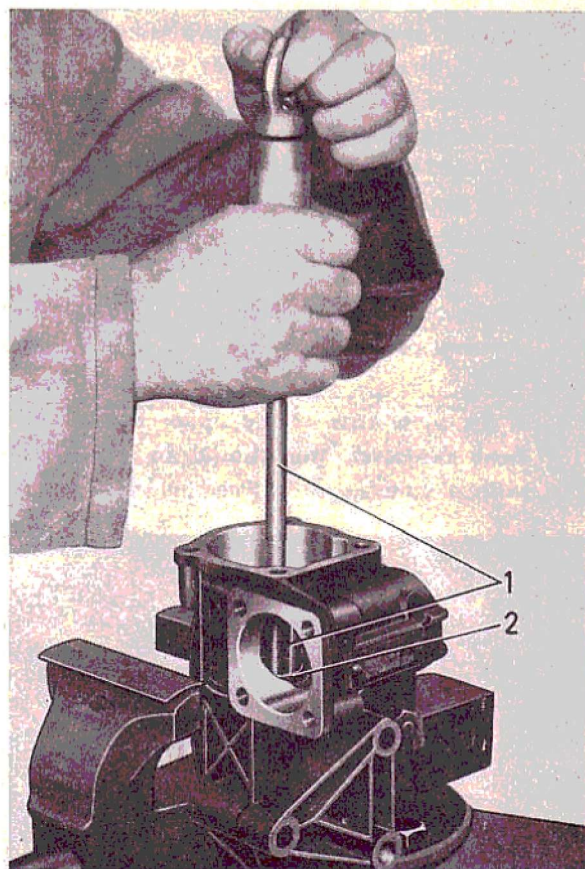
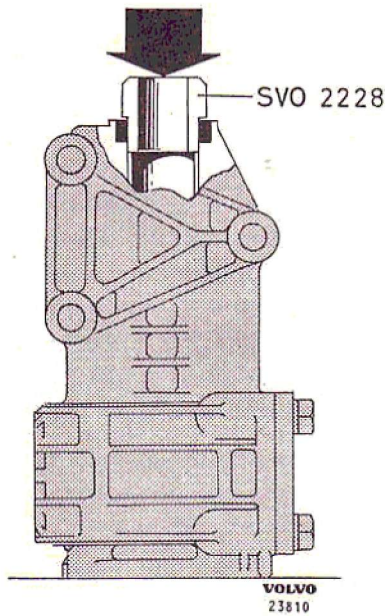

Fig. 35. Fitting the pitman arm shaft bush.

### Assembling

1. Press in the pitman arm shaft bushes from either direction with drift SVO 2228 and standard handle SVO 1801, see Fig. 35. Ream the bushes with reamer SVO 2225. Use guide SVO 2254, which is attached to the housing with two bolts, see Fig. 36. Thoroughly clean all metal shavings from the housing after reaming.
2. Fit the oil seals for the pitman arm shaft and steering column with the help of drift SVO 2227.
3. If the outer race of the upper bearing has been removed, this should be pressed in with a suitable drift. Press it in so that it

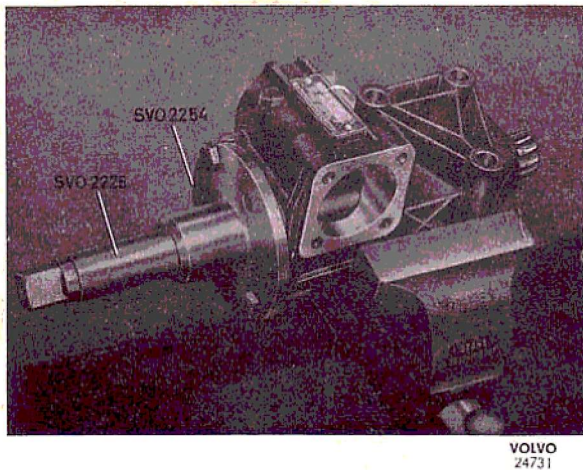

Fig. 36. Reaming the pitman arm shaft bushes.

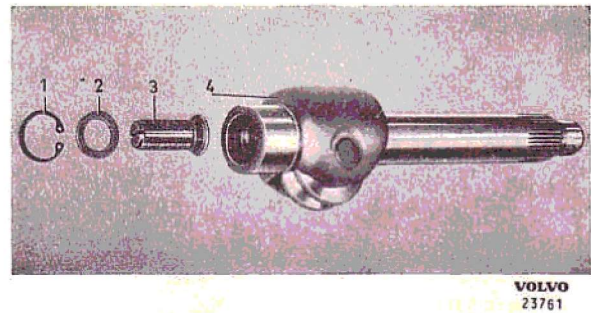

Fig. 37. Pitman arm shaft.

- |                    |                                 |
|--------------------|---------------------------------|
| 1. Circlip         | 4. Pitman arm shaft with roller |
| 2. Washer          |                                 |
| 3. Adjusting screw |                                 |

lies flush against the shoulder in the housing.

4. Fit the steering column with bearings in the housing carefully so as not to damage the oil seal. Secure the steering box in a vice so that the steering column comes horizontally. Fit the lower cover and washer together with shims of the same thickness as were fitted previously. Tighten the cover while checking that the steering column turns easily but without any play. When the bearings are correctly adjusted, it should require a torque of 1–2.5 kgcm (0.87–2.17 lb.in.) to turn the steering column.
5. Fit the adjusting screw, washer, and circlip on the pitman arm shaft, see Fig. 37. The axial clearance of the adjusting screw should not exceed 0.05 mm (0.002"). The clearance is reduced by replacing the washer (2) with a thicker one. The adjusting screw should, however, be easy to turn after fitting.
6. Apply the protecting sleeve SVO 2199 as shown in Fig. 38 and fit the pitman arm shaft in the steering box housing. Oil the adjusting screw in the pitman arm shaft with a few drops of oil.
7. Fit the cover and gasket over the pitman arm shaft. Screw up the adjusting screw sufficiently far so that the pitman arm shaft is not pinched when the attaching bolts are tightened.
8. Set the steering column to the central position. Screw in the adjusting screw until a noticeable resistance is felt when turning backwards and forwards over the central position.

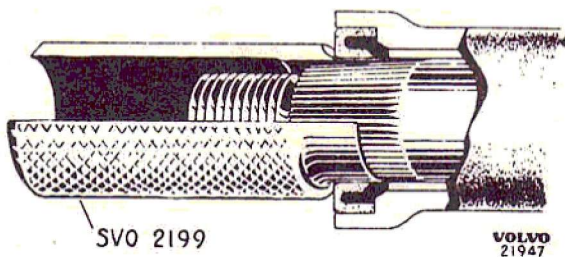

Fig. 38. Fitting the pitman arm shaft.

Attach a spring-balance at a distance of 210 mm (8 1/4") from the pivoting centre. The spring-balance can be hooked onto a suitable pivoting arm fitted on the steering column as shown in Fig. 39.

Screw back the adjusting screw until the spring-balance gives a reading of 0.4–0.7 kg (0.88–1.54 lb.) when it turns the steering column over the central position. Pulling should be done at right-angles to the steering column and the steering box should be secured in such a way that the steering column is vertical when measuring. When the correct adjustment has been obtained, the adjusting screw is locked with the stop nut. Repeat the test after the stop nut has been tightened.

9. Fit the clamp on the steering column in the same position it had before removing.
10. Fill up the steering box with 0.25 litre (3/8 Imp. pint = 1/2 US pint) of SAE 80 hypoid oil.

In order to obtain the best possible steering properties, a new steering gear should be adjusted after the first 5 000–10 000 km (3 000–6 000 miles). Adjusting should be carried out in accordance with point 8 and with the pitman arm removed.

### Installing, P 120

1. Place the steering box in position. Be careful when moving the clamp past the brake line. Fit the attaching bolts (6, Fig. 30).
2. Assemble the clamp (5) to the coupling disc (3). Do not forget the earth lead (1).
3. Adjust the position of the steering box so that there is the least possible strain on the coupling disc, i.e. the upper and lower sections of the steering column should form a straight line. Tighten the attaching bolts (6).

4. Fit the pitman arm so that the line-up mark on the pitman arm shaft coincides with the mark on the pitman arm. Tighten the nut to a torque of 13.5–16.5 kgm (100–120 lb.ft.).
5. Check that the steering wheel spokes are horizontal when the wheels point straight forwards. If not, take off the steering wheel and alter its position. See under "Replacing the steering wheel".

### Installing, P 1800

1. Insert the horn lead through the lower section of the steering column with the help of a piece of iron wire through the steering box if necessary. Place the steering box in position and fit the attaching bolts, washers and nuts loosely.
2. Fit the clamp to the coupling disc, see Fig. 32. Do not forget the earth lead.
3. Adjust the position of the steering box so there is the least possible stress on the coupling disc. Tighten the steering box attaching nuts.
4. Fit the pitman arm so that the line-up mark

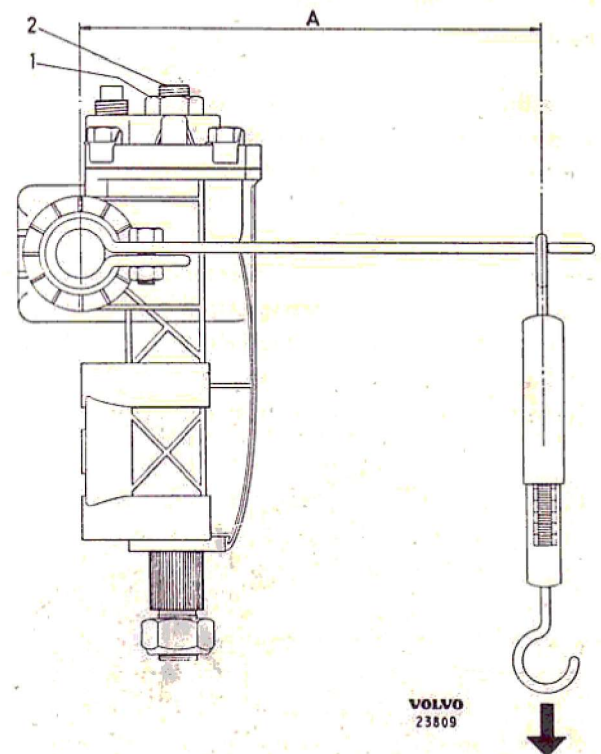

Fig. 39. Checking the take-up between the cam and roller.

"A" = 210 mm (8 1/4")

1. Locknut
2. Adjusting screw

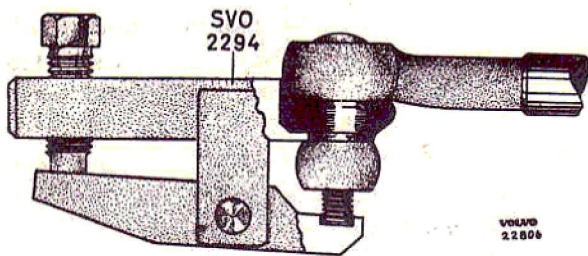

Fig. 40. Removing ball joint.

on the pitman arm shaft coincides with the mark on the pitman arm.

5. Check that the steering wheel spokes are horizontal when the wheels are pointing straight forwards. If not, remove the steering wheel and alter its position, see under "Replacing the steering wheel". Connect the horn lead.

### RECONDITIONING THE STEERING ROD AND TIE ROD

The steering rod and tie rod must not be straightened, but any rod which is bent or damaged must be replaced.

The ball joints cannot be dismantled or adjusted so that when worn or damaged they must be replaced.

The steering rod ball joints are made integrally with the steering rod so that the rod must be replaced complete. When removing, the split pins and castle nuts are first removed. Tool SVO 2294 is then placed on the ball joint as shown in Fig. 40. Press in the tool properly and make sure that the thread on the ball joint enters the recess in the tool. Screw in the screw until the ball joint releases. If the steering rod is to be removed without taking off the wheels, the ball joint on the pitman arm or relay arm respectively must

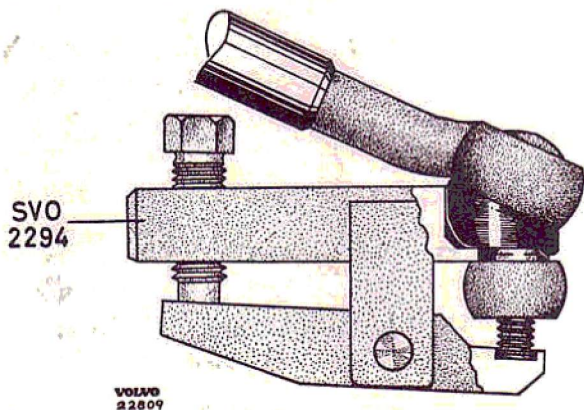

Fig. 41. Removing the steering rod.

first be taken off as described above. When doing this the steering rod is turned forwards and upwards and the tool placed on the ball joint.

The tie rod ball joints can be replaced independently. When replacing, the ball joint is first disconnected from the pitman arm or relay arm respectively as described above, see Fig. 40. The locknut or clamping screw respectively is then slackened and the ball joint screwed out. To start with, the new ball joint is screwed in the same number of turns in order to facilitate adjusting the toe-in. Lock the ball joint to the rod.

On early production ball studs with 10×1 mm thread the tie rod stop nut is threaded on the ball joint. Late production ball joints with 318"—24 UNF thread can be recognized partly by a 25 mm (1") wide yellow stripe, and partly by the tie rod stop nut being threaded on the rod.

When replacing the ball joint rubber covers, these should be filled with grease. When the ball joint is fitted to the pitman arm, the ball stud is turned so that the split pin hole is located across the longitudinal direction of the rod. Tighten the castle nut to a torque of 3.2–3.7 kgm (23–27 lb.ft.) and lock it with a split pin.

After completing reconditioning work on the rods and ball joints, the toe-in must always be checked.

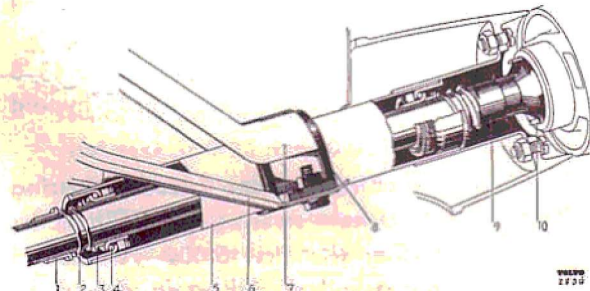

Fig. 42. Steering column bearings, late production, P 120.

- |                 |  |
|-----------------|--|
| 1. Sleeve       | 6. Steering column stay (early production) |
| 2. Spring       | 7. Steering column, upper                  |
| 3. Seat         | 8. Rubber bush                             |
| 4. Ball bearing | 9. Connecting piece                        |
| 5. Jacket tube  | 10. Serrated pin                           |

### REPLACING THE JACKET TUBE AND JACKET TUBE MOUNTINGS, P 120

1. Remove the steering wheel, see under "Replacing the steering wheel".
2. Unscrew the bolts for the attachment. Remove the direction indicator switch and con-

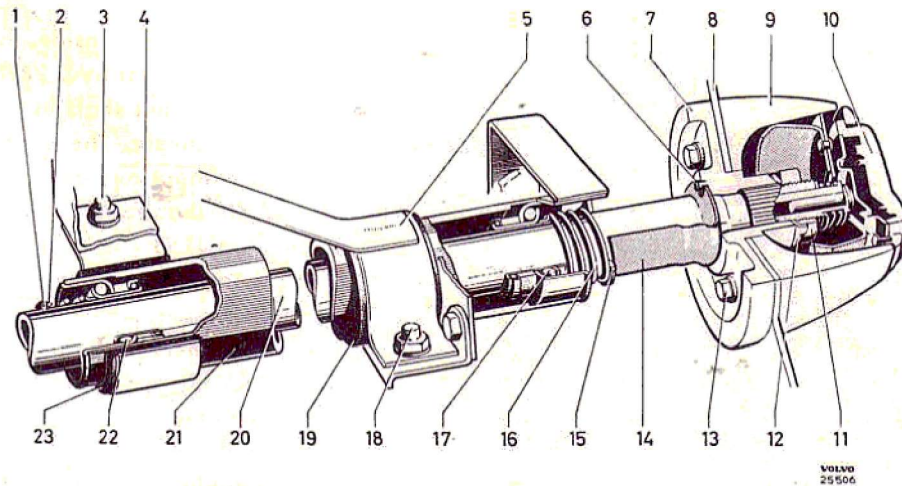

Fig. 43. Steering column mounting, P 1800.

- |                     |                       |                        |                     |                   |
|---------------------|-----------------------|------------------------|---------------------|-------------------|
| 1. Circlip          | 6. Guide pin          | 11. Steering wheel nut | 16. Spring          | 21. Jacket tube   |
| 2. Spring           | 7. Steering wheel hub | 12. Locking washer     | 17. Upper bearing   | 22. Lower bearing |
| 3. Bolt             | 8. Steering wheel     | 13. Bolt               | 18. Bolt            | 23. Rubber bush   |
| 4. Lower attachment | 9. Casing             | 14. Connecting piece   | 19. Rubber bush     |                   |
| 5. Upper attachment | 10. Horn button       | 15. Washer             | 20. Steering column |                   |

trol lever, see Part 3. Then pull the jacket tube off the steering column.

- If only the bushes or bearings in the jacket tube are to be replaced, the old ones are first knocked out with a suitable drift or pulled out with a puller. After this the new parts are carefully pressed into the jacket tube.
- Check that the rubber bushes for the jacket tube attachments are undamaged. Then fit the jacket tube and other parts in the reverse order to removing and as shown in Fig. 42 in the case of late production. The bushes on the early production type should be smeared with a thin coating of ball bearing grease. Tighten the steering wheel nut to a torque of 3.5–5.0 kgm (25–35 lb.ft.) and do not forget to lock it.

### REPLACING THE JACKET TUBE AND JACKET TUBE MOUNTINGS, P 1800

- Remove the steering wheel, see under "Replacing the steering wheel".
- Unscrew the bolts (3, Fig. 43) for the lower attachment and the bolt (18) for the upper attachment. Pull up the jacket tube (21) slightly and remove the direction indicator switch and control lever, see Part 3. Then pull off the jacket tube from the steering column (20).
- If only the bearings (17 and 22) in the jacket

tube are to be replaced, the old ones are first knocked out with the help of a suitable drift or pulled out with a puller. After this the new parts are carefully pressed into the jacket tube.

- Check that the rubber bushes (19 and 23) for the jacket tube attachment are undamaged and that the circlip (1) is located in its groove. Then fit the jacket tube and other parts in the reverse order to removing and as shown in Fig. 43. Tighten the steering wheel nut to a torque of 3.5–5.0 kgm (25–35 lb.ft.) and do not forget to lock it.

### RECONDITIONING THE RELAY ARM AND BRACKET

#### Removing

- Jack up the front end and place blocks under the lower wishbones.
- Screw back the screw on puller SVO 2294 and place the tool on the tie rod ball joint at the relay arm as shown in Fig. 40. Press in the tool properly and make sure that the thread on the ball joint enters the recess in the tool. Screw in the screw until the ball joint releases from the relay arm.
- Disconnect the steering rod from the relay arm in a similar manner.
- Remove the three attaching bolts for the bracket and lift off the bracket with relay arm.

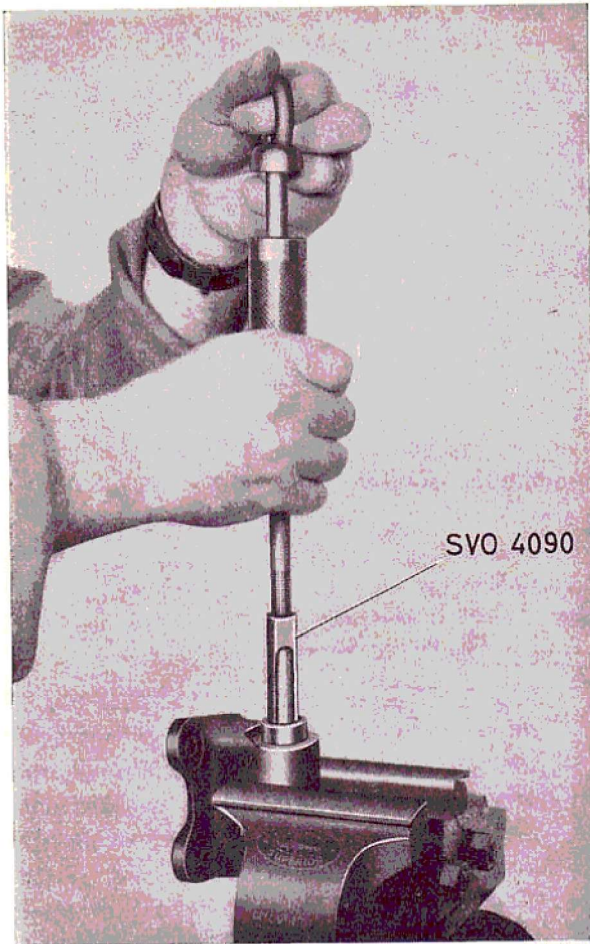

Fig. 44. Removing needle bearing. VOLVO 23750

**Dismantling**

1. Remove the split pin or circlip respectively and the nut. On the late production of type III there is no circlip. Pull out the relay arm with shaft. Take care of the washers and shims.
2. Secure the bracket in a vice and pull out the needle bearings with a bearing puller, for example, SVO 4090, see Fig. 44. The bushes are removed with drift SVO 2498.

**Assembling**

1. Press in the new needle bearings or bushes respectively. In the case of relay arm mounting type I (Fig. 24), pressing in is done flush with the outer side. On type II (Fig. 25), the needle bearings are pressed in so that the measurement A is 3.2–3.5 mm (0.126–0.138"). The oil seals are fitted in these gaps with the lip turned outwards. On type III (Fig. 26), the bushes are pressed in 0.3–0.5

mm (0.012–0.020") inside the outer face with the help of drift SVO 2498, see Fig. 45. Check the fit of the shaft in the bearings or bushes respectively. The shaft should turn easily but without any play.

On type III the bushes are reamed with reamer SVO 4153.

2. Fill the bearings and the space between them with chassis grease. Also lubricate the vulcollan washers on both sides.
3. Fit the other parts as shown in Figs. 24–26. The nut is tightened to a torque of 8.5 kgm (60 lb.ft.).
4. After assembling there must be no play in the bearings. When adjusted correctly, a turning torque of  $15 \pm 5$  kgcm ( $13 \pm 4.3$  lb. in.) is required. For example, when pulling on the relay arm at the steering rod hole (the inner hole) at right-angles, a spring-balance should give a reading of 0.7–1.3 kg (1.54–2.86 lb.). If this result is not obtained when checking, the bearing mountings must be taken apart and adjusted with shims of suitable thickness.

When the correct torque has been obtained the split pin or circlip respectively is fitted. On late production type III there is no circlip.

**Installing**

Fit the bracket in position and tighten the attaching bolts well. Fit the steering rod in the inner hole of the relay arm and the tie rod in the outer hole. Tighten the castle nuts to a torque of 3.2–3.7 kgm (23–27 lb.ft.) and lock them with split pins.

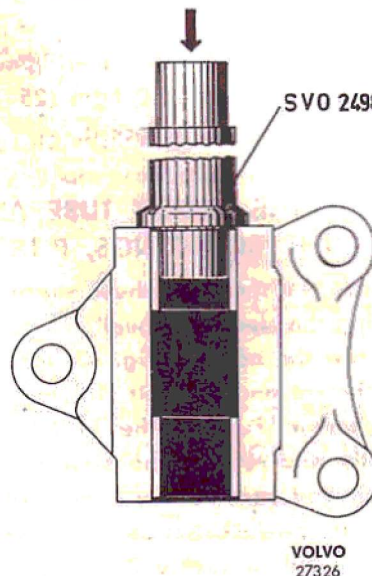

Fig. 45. Fitting the bush. VOLVO 27326

# FAULT TRACING

<b>FAULT</b>	
<b>REASON</b>	<b>REMEDY</b>

## THE CAR WANDERS

Faulty caster.  
Excessive or insufficient play in the steering box.  
Steering rod ball joints worn or binding.

Check and adjust the caster.  
Adjust the steering box.  
Examine the ball joints and replace any which are worn. Ball joints with grease nipples should be lubricated.

Faulty toe-in.  
Wishbone system binding.

Check and adjust the toe-in.  
Carry out thorough lubrication. Replace any damaged parts.

## THE CAR PULLS TO EITHER SIDE

Insufficient or uneven tyre pressure.  
The front springs are fatigued or have different heights.  
One of the roller bearings is taken up too tightly.

Check the tyre pressure (see Part 7).  
Remove and check the springs (see Part 7).

Faulty tracking.

Check the bearings. Replace any damaged bearings and adjust (see Part 7).  
Carry out check measurements on the body and adjust if necessary (see Part 8).

Dragging brakes.  
Bent steering rod.  
Faulty camber.

Adjust the brakes (see Part 5).  
Replace the damaged rod.  
Check and adjust the camber.

## HARD OR STIFF STEERING

Binding or damaged ball joints.  
Unsuitable or insufficient lubricant in the steering box.  
Steering box adjusted too tightly.  
Steering rod ball joints or relay arm bearings binding.

Replace the ball joints.  
Check the oil. Concerning oil quality, see "Specifications".  
Adjust the steering box.  
Lubricate the joints and remove the bracket for the relay arm and examine the bearings. Replace any other parts.

Excessive caster.

Check and adjust the caster.

## JAZZING

Wheels out-of-balance or warped.  
One of the brake drums out-of-round.  
Insufficient air pressure in the tyres.  
Damaged steering rod.  
Loose or worn front wheel bearings.

Balance the wheels and correct them if necessary (see Part 7).  
See Part 5.  
Check the tyre pressure (see Part 7).  
Replace the damaged rod.  
Remove the wheels and hubs. Examine the bearing races. If any part is damaged, replace the complete bearing (see Part 7).

**SHOCKS AND IMPACTS IN THE STEERING WHEEL**

Excessive play in steering box.  
 Unsuitable or insufficient lubricant in the steering box.  
 Play in the front wheel bearings.

Play in steering rod ball joints.  
 Incorrectly fitted pitman arm.  
 Wheels out-of-balance or warped.

Adjust the steering box.  
 Check the oil. Concerning oil quality, see "Specifications".  
 See under the heading "Front wheel bearings" (see Part 7).  
 Replace any loose ball joints.  
 See pages 6—18.  
 Balance the wheels and correct them if necessary (see Part 7).

**TOOLS**

The following special tools are required for repairs to the front axle and steering gear

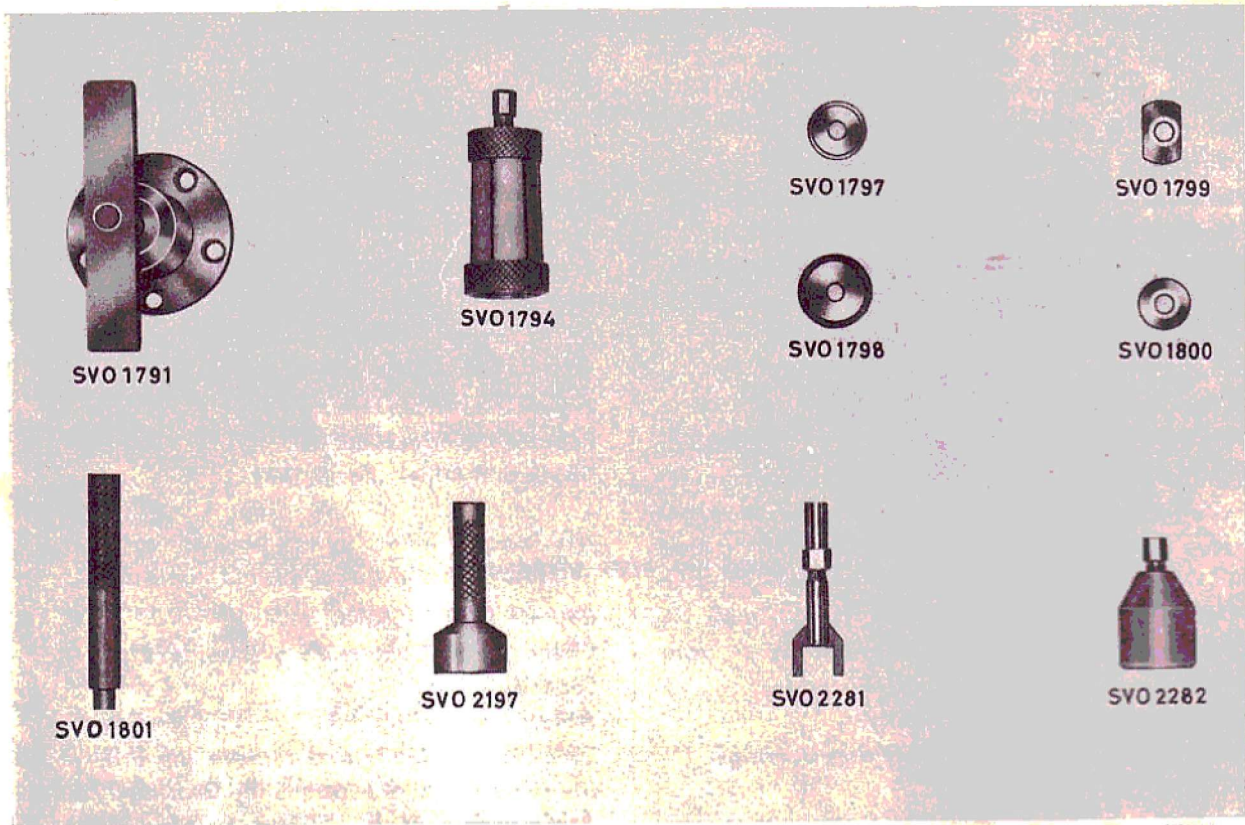

VOLVO  
23865

Fig. 46. Special tools for front axle.

**FRONT AXLE**

- |          |  |          |   |
|----------|--|----------|---|
| SVO 1791 | Puller for wheel hub.                                  | SVO 1800 | Drift for removing outer race, outer wheel bearing. |
| SVO 1794 | Puller for inner ring, inner wheel bearing.            | SVO 1801 | Standard handle 18 X 200.                           |
| SVO 1797 | Drift for fitting outer wheel bearing.                 | SVO 2197 | Drift for fitting and removing grease cap.          |
| SVO 1798 | Drift for fitting inner wheel bearing and seal in hub. | SVO 2281 | Tool for removing lower ball joint, wishbone.       |
| SVO 1799 | Drift for removing inner wheel bearing.                | SVO 2282 | Puller for pitman arm.                              |

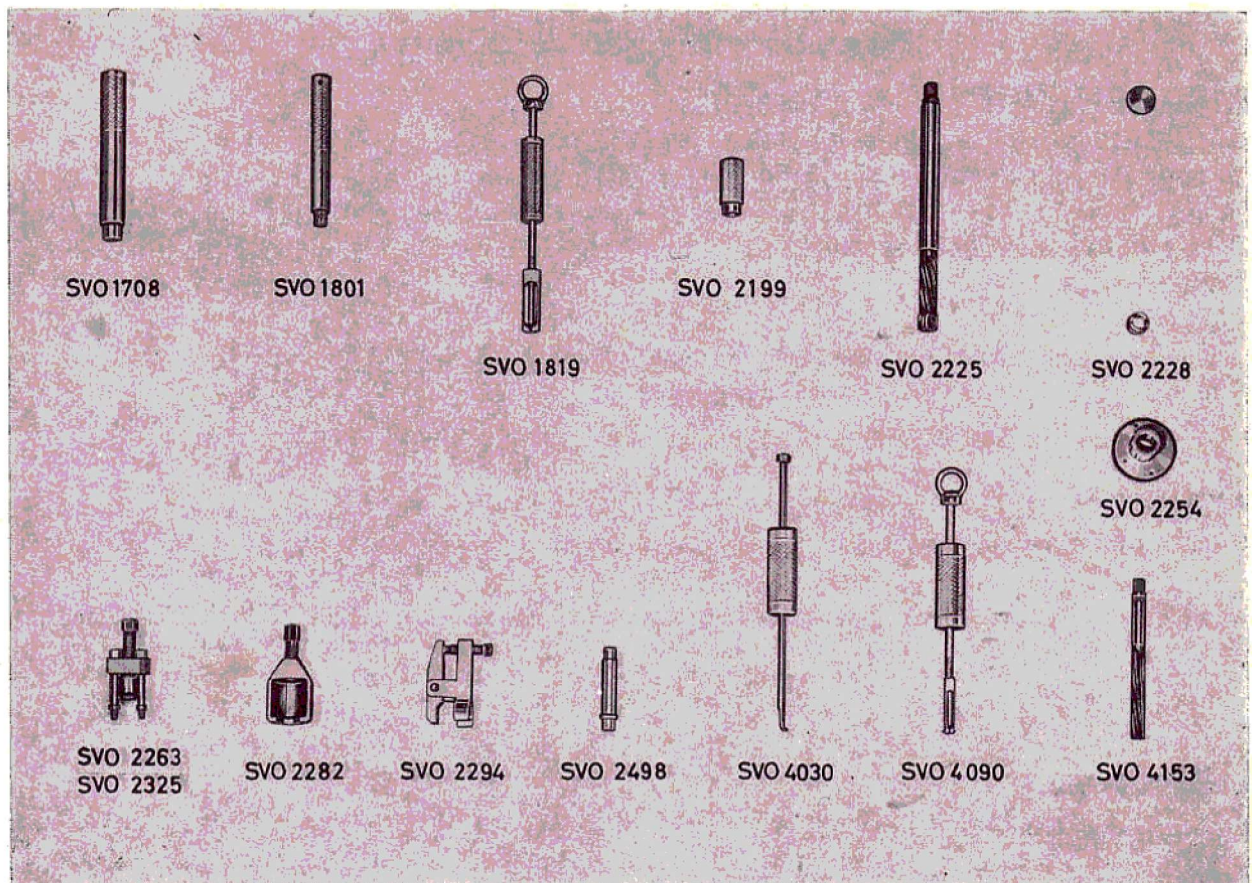

Fig. 47. Special tools for steering gear.

### STEERING GEAR

SVO 1708	Drift for removing upper outer bearing race (steering column bearing).	SVO 2282	Puller for pitman arm.
SVO 1801	Standard handle.	SVO 2294	Puller for ball joint, tie rod and steering rod.
SVO 1819	Puller for pitman arm shaft bushes.	SVO 2325	Steering wheel puller with effect from P 120 E (2-door), P 120 K (4-door). <sup>1)</sup>
SVO 2199	Protecting sleeve for seal when fitting pitman arm shaft.	SVO 2498	Drift for fitting and removing bushes in relay arm bracket.
SVO 2225	Reamer for pitman arm shaft bushes.	SVO 4030	Puller for oil seals.
SVO 2227	Drift for fitting pitman arm shaft seal.	SVO 4090	Puller for needle bearing in relay arm bracket.
SVO 2228	Drift for fitting pitman arm shaft bushes.	SVO 4153	Reamer for bushes in relay arm bracket.
SVO 2254	Guide for reamer SVO 2225.		
SVO 2263	Steering wheel puller, all P 120 up to P 120 D (2-door), P 120 G (4-door) and P 120 Station Wagon. <sup>1)</sup>		

<sup>1)</sup> On certain of the late production vehicles, SVO 2263 must be used.

# SPECIFICATIONS

## WHEEL ALIGNMENT (vehicle unloaded)

Caster (P 120 up to chassis No. 2610) .....	-1/2 to +1/2°
Caster (P 120 with effect from chassis No. 2611, P 1800) .....	0 to +1°
Camber .....	0 to +1/2°
"King pin" inclination at 0° camber .....	8°
Toe-in .....	0 to 4 mm (5/32")
Toe-out:	
When the outer wheel is turned 20°, the inner wheel should be turned .....	21.5 to 23.5°

## FRONT AXLE

Shims for front axle member .....	thickness = 2 mm (0.079")
	thickness = 3 mm (0.118")
Shims for upper wishbone .....	thickness = 0.15 mm (0.006")
	thickness = 0.5 mm (0.020")
	thickness = 1 mm (0.039")
	thickness = 3 mm (0.118")
	thickness = 6 mm (0.236")

## STEERING GEAR

Steering wheel diameter:	
P 120 .....	430 mm (17")
P 1800 .....	406.4 mm (16")
Number of turns (from lock to lock) .....	3 1/4
Steering box, make and type .....	Gemmer, "cam and roller"
Steering box, reduction ratio .....	15.5:1
Shims for steering box bearing .....	thickness = 0.10 mm (0.0039")
	thickness = 0.12 mm (0.0047")
	thickness = 0.15 mm (0.0059")
	thickness = 0.30 mm (0.0118")
Washer between adjusting screw and pitman arm shaft (in steps of 0.05 mm = 0.002") .....	2.20-2.45 mm (0.0866-0.0965")
Lubricant for steering box .....	Hypoid oil SAE 80
Oil capacity .....	0.25 litre (3/8 Imp. pint = 1/2 U.S. pint)
Relay arm:	
Necessary turning torque .....	10-20 kgcm (8.7-17.0 lb.in.)
Shims .....	thickness = 0.1 mm (0.0039")
	thickness = 0.15 mm (0.0059")
	thickness = 0.35 mm (0.0138")

## TIGHTENING TORQUES

Nut for relay arm shaft, early production .....	7 kgm (50 lb.ft.)
Nut for relay arm shaft, late production with Nyloc nut .....	8.5 kgm (60 lb.ft.)
Steering wheel nut .....	3.5-5.0 kgm (25-35 lb.ft.)
Nut for pitman arm .....	13.5-16.5 kgm (100-120 lb.ft.)
Castle nut for steering rod and tie rod .....	3.2-3.7 kgm (23-27 lb.ft.)
Nut for wishbone clamp .....	2.0-2.5 kgm (14-18 lb.ft.)
Bolt for upper wishbone shaft .....	4.8-5.5 kgm (35-40 lb.ft.)



